

NorthStar brand

Instruction Manual

SLIM Tach® SL85

Magneto-resistive Encoder

Designed for use in

0.625" to 3.000" (16mm to 76mm)

Shaft Diameters



1675 Delany Road * Gurnee, IL * 60031 * USA

Customer Service:

Tel.: +1.800.873.8731

Fax: +1.847.662.4150

northstar.custserv@dancon.com

Technical Support

Tel.: +1.800.234.8731

Fax: +1.847.782.5277

northstar.techsupport@dancon.com

Website: www.dynapar.com

* 791-1008-00 *

Table of Contents

| Chapter/Paragraph/Illustration | Page |
|---|------|
| 1 Introduction | 4 |
| 1.0 Safety Summary | 4 |
| 1.1 General | 5 |
| 1.2 Description | 5 |
| <i>Figure 1: SLIM Tach® SL85 Thru-Shaft Exploded View w/ Spare Parts</i> | 5 |
| 1.3 Specifications | 6 |
| 2 Installation | 7 |
| 2.0 Inspection and Unpacking | 7 |
| 2.1 Motor Facing and Shaft for Thru-Shaft SL85 | 7 |
| <i>Figure 2: Typical 8.5 Inch Diameter Type C-Face Motor Thru-Shaft Application</i> | 7 |
| 2.1.1 Encoder Frame Installation | 8 |
| <i>Figure 3: Typical Motor Mounting</i> | 8 |
| 2.1.2 Thru-Shaft Pulse Wheel Installation | 9 |
| <i>Figure 4: Pulse Wheel Orientation</i> | 9 |
| <i>Figure 5: SLIM Tach® SL85 End-of-Shaft Exploded View</i> | 10 |
| 2.2 Motor Facing and Shaft for End-of-Shaft SL85 | 11 |
| <i>Figure 6: Typical 8.5 Inch Diameter Type C-Face Motor End-of-Shaft Application</i> | 11 |
| 2.2.1 Encoder Frame Installation | 11 |
| 2.2.2 End-of-Shaft Pulse Wheel Installation | 11 |
| <i>Figure 7: Pulse Wheel Assembly</i> | 12 |
| 2.3 Electrical Installation | 12 |
| 2.3.1 Quick Release Connector Hood Wiring | 13 |
| <i>Figure 8: Sealed Industrial Latching Connector</i> | 13 |
| 2.3.2 Returning Equipment to Dynapar | 14 |

Methods and apparatus disclosed and described herein have been developed solely on company funds of Dynapar No government or other contractual support or relationship whatsoever has existed which in any way affects or mitigates proprietary rights of Dynapar in these developments. Methods and apparatus disclosed herein may be subject to U.S. Patents existing or applied for. Dynapar reserves the right to add, improve, modify, or withdraw functions, design modifications, or products at any time without notice. Dynapar shall not be liable for errors contained herein or for incidental or consequential damages in connection with furnishing, performance, or use of this material.

CHAPTER 1

INTRODUCTION

1.0 Safety Summary

High current, voltage, and rotating parts can cause serious or fatal injury. The use of electric machinery, like all other uses of concentrated power and rotating equipment, may be hazardous. Installing, operating, and maintaining electric machinery should be performed by qualified personnel, in accordance with applicable provisions of the National Electrical Code and sound local practices. Failure to comply with these precautions or with specific warnings elsewhere in this manual violates safety standards of design, manufacture, and intended use of the instrument. Dynapar assumes no liability for the customer's failure to comply with these requirements.

Rotating Machinery

Avoid contact with rotating parts. Avoid by-passing or rendering inoperative any safety guards or protection devices. Avoid extended exposure in close proximity to machinery with high noise levels. Use proper care and procedures in handling, lifting, installing, operating and maintaining the equipment.

Before Installation

Safe maintenance practices with qualified personnel is imperative. Before starting maintenance procedures, be positive that, (1) equipment connected to the shaft will not cause mechanical rotation, (2) main machine windings have been disconnected and secured from all electrical power sources, and (3) all accessory devices associates with the work area have been de-energized. If high potential insulation test is required, follow procedures and precautions outlined in NEMA standards MG-1.

Grounding

Improperly grounding the frame of the machine can cause serious or fatal injury to personnel. Grounding of the machine frame and structure should comply with the National Electrical Code and with sound local practices. Check wiring diagram before connecting power.

Do Not Operate In An Explosive Atmosphere

Do not operate the instrument in the presence of flammable gases or fumes. Operating any electrical instrument in such an environment constitutes a definite safety hazard.

Keep Away From Live Circuits

Operating personnel must not remove instrument covers. Component replacement and internal adjustments must be made by qualified maintenance personnel. Do not replace components with power cable connected. To avoid injuries, always disconnect power and discharge circuits before touching them.

Do Not Substitute Parts Or Modify Instrument

Do not install substitute parts or perform any unauthorized modification to the instrument. Introducing additional hazards is dangerous. Return the instrument to an authorized Dynapar representative for service and repair to ensure that safety features are maintained.

Dangerous Procedure Cautions

A CAUTION heading precedes potentially dangerous procedures throughout this manual. Instructions in the warnings *must* be followed.

1.1 General

These instructions do not claim to cover all details of variation in equipment or to provide for every possible contingency or hazard to be met in connection with installation, operation, and service. Should further information be desired or should particular problems arise which are not covered sufficiently for the purchaser's purposes, please contact Dynapar, or one of its designated representatives.

1.2 Description

The NorthStar SLIM Tach® SL85 is a modular digital encoder. This magneto-resistive encoder sensor-based unit was designed for fast, easy mounting onto a standard NEMA 8.5 inch motor face. The basic design philosophy follows. The encoder frame is mounted onto the C-Face flange of a motor. This positions the sensor and contains the electronics. The magnetic pulse wheel on the motor shaft has magnetic pulses imprinted on its outside surface. As the motor spins, the passing magnetic pulses actuate the magneto-resistive sensor. The resulting electronic signals are processed into square wave signals by the internal electronics.

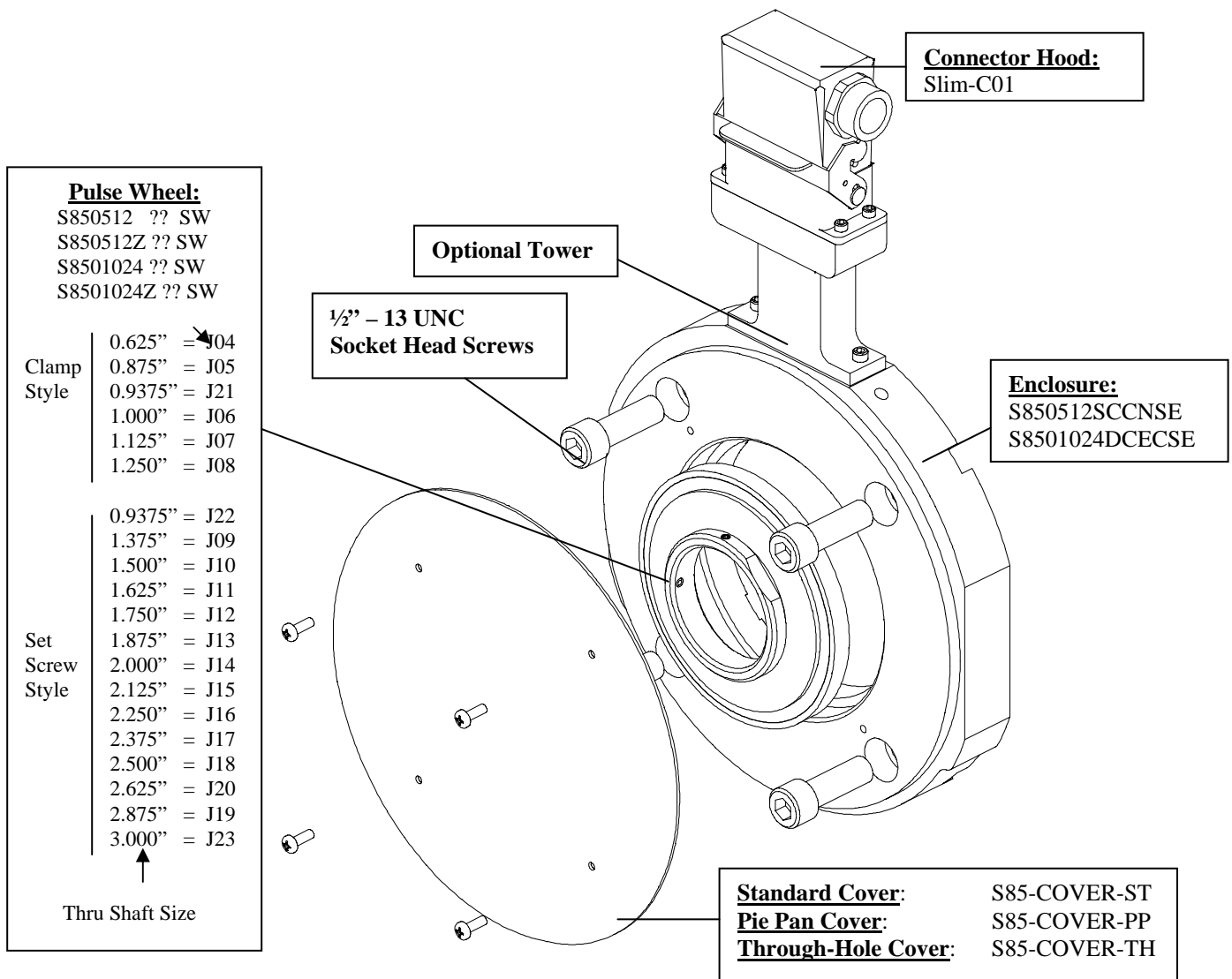

Figure 1: SLIM Tach® SL85 Thru-Shaft Exploded View w/ Spare Parts (Shown w/ Optional Tower)

NOTE: If you have further questions, please call Dynapar customer service (614) 818-1150+ext. 282 or 278 with serial number ready.

1.3 Specifications

| Electrical Specifications | |
|--|---|
| Resolution | 512, 512Z, 1024, 1024Z, 2048 PPR |
| Frequency Response | 0 to 120KHz Max. |
| Pulse Code | Incremental, marker, quadrature, complements (A, B, Z) |
| Output Channels | A & B (incremental), Z (marker) |
| Duty Cycle | 50 ± 15% (within defined mechanical specs) |
| Quadrature Accuracy | A-B 90° ± 22° |
| Output Type | High Speed, Differential Driver |
| Rise and Fall Time | Less than 500 ns @ 10,000 pf (typical) |
| Current Consumption | 40 mA typical plus line driver load |
| ESD Protection | 2 kV |
| Output Current Capability | 150 mA typical [350 mA maximum (worst case)] |
| Connector | 10 pin Epic style, NEMA 4, 12 industrial connector |
| Suggested Cable | 22 AWG, 8 conductor, 18" length, 4 twisted shield pairs |
| Input Voltage | +5.0 to +15.0 VDC |
| Mechanical Specifications | |
| Maximum Operational Speed | 5,000 RPM |
| Nominal Air Gap | 0.019 ± 0.008 inch |
| Shaft Axial End Play | Up to ± 0.045 inch maximum |
| Enclosure Configuration | 4.5 - Inch Diameter, 56 C motor face or accessory flange to meet NEMA MG1-4 standards |
| Slew Rate | 12,000 RPM per second |
| Approximate Box Weight | 4lbs. (1.81 Kg) |
| Box Dimension | 17.5" x 10.75" x 2.75" |
| Common Environmental Specifications | |
| Operational Temperature | -40° to + 90° C |
| Operational Humidity Range | Maximum of 98% |
| Chemical Resistance | Salt Spray, Most Solvents, Mild Acids and Bases |
| Vibration | Minimum 18 g's RMS, 5-2000 Hz |
| Shock (Encoder Housing) | 1 meter drop tested, min 30 g's shock spectrum |

Specifications subject to change without notice

CHAPTER 2

INSTALLATION

2.0 Inspection and Unpacking

Inspect shipping container for external damage. All claims for damage (apparent or concealed) or partial loss of shipment must be made in writing to Dynapar within (5) days from receipt of goods. If damage or loss is apparent, please notify the shipping agent immediately.

Open shipping container and locate the packing list. The packing list is included to verify that all components, accessories, and manual were received. Please use the packing list to check off each item as the unit is unpacked. Inspect for damage. We recommend that the shipping container be retained for future shipping, storage, or return to factory purposes.

If any equipment was damaged in transit, be sure to file proper claims promptly with the carrier and insurance company. Please advise us of such filing. In case of parts shortages, advise us immediately. Dynapar cannot be responsible for any missing parts unless notified within 60 days of shipment.

Motor Facing and Shaft for Thru-Shaft SL85

To prepare the motor facing and shaft for installation, perform the following steps. See Figure 2.

1. Clean outer rim and mounting surface of motor facing and shaft of paint, grease, dirt, and other debris where SLIM Tach® SL85 unit contacts motor or accessory. Also ensure that mating surfaces have not been damaged and that unit will fit squarely on motor.
2. Apply a thin layer of corrosion preventative or oil to motor facing and shaft to aid assembly and provide some corrosion protection.

CAUTION!

Ensure there is no paint, burrs, protrusions, or deformations on the motor facing or shaft. If the enclosure does not fit squarely on the motor facing, the alignment between the encoder frame and the magnetic pulse wheel may be degraded.

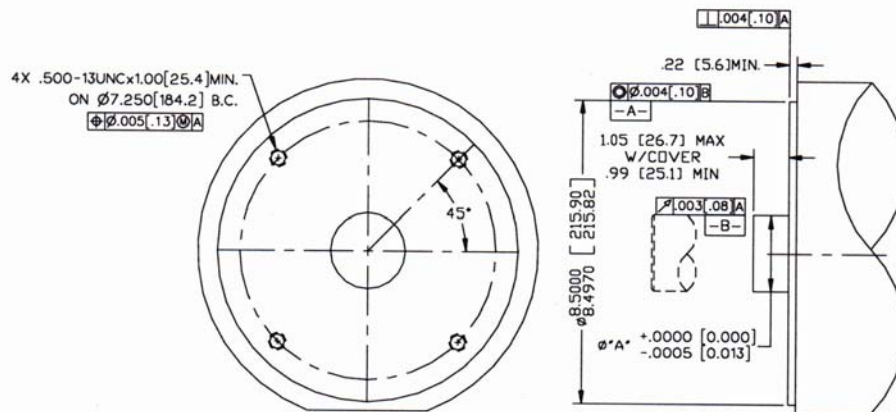

2.1.1 Encoder Frame Installation

To install the encoder frame, perform the following steps.

1. Orient the encoder frame so the 8.5 inch I.D. surface will fit over the 8.5 inch C flange (encapsulated side toward the motor). Mount frame onto the motor flange. Insert the four 1/2 inch x 13 UNC socket head cap screws through the frame and into the motor frame. Use a 3/8 inch hex wrench to tighten a nominal 25 foot pounds. See Figure 3.

NOTE

On End-of-Shaft units, one may wish to mount the encoder frame after mounting the pulse wheel. See page 10.

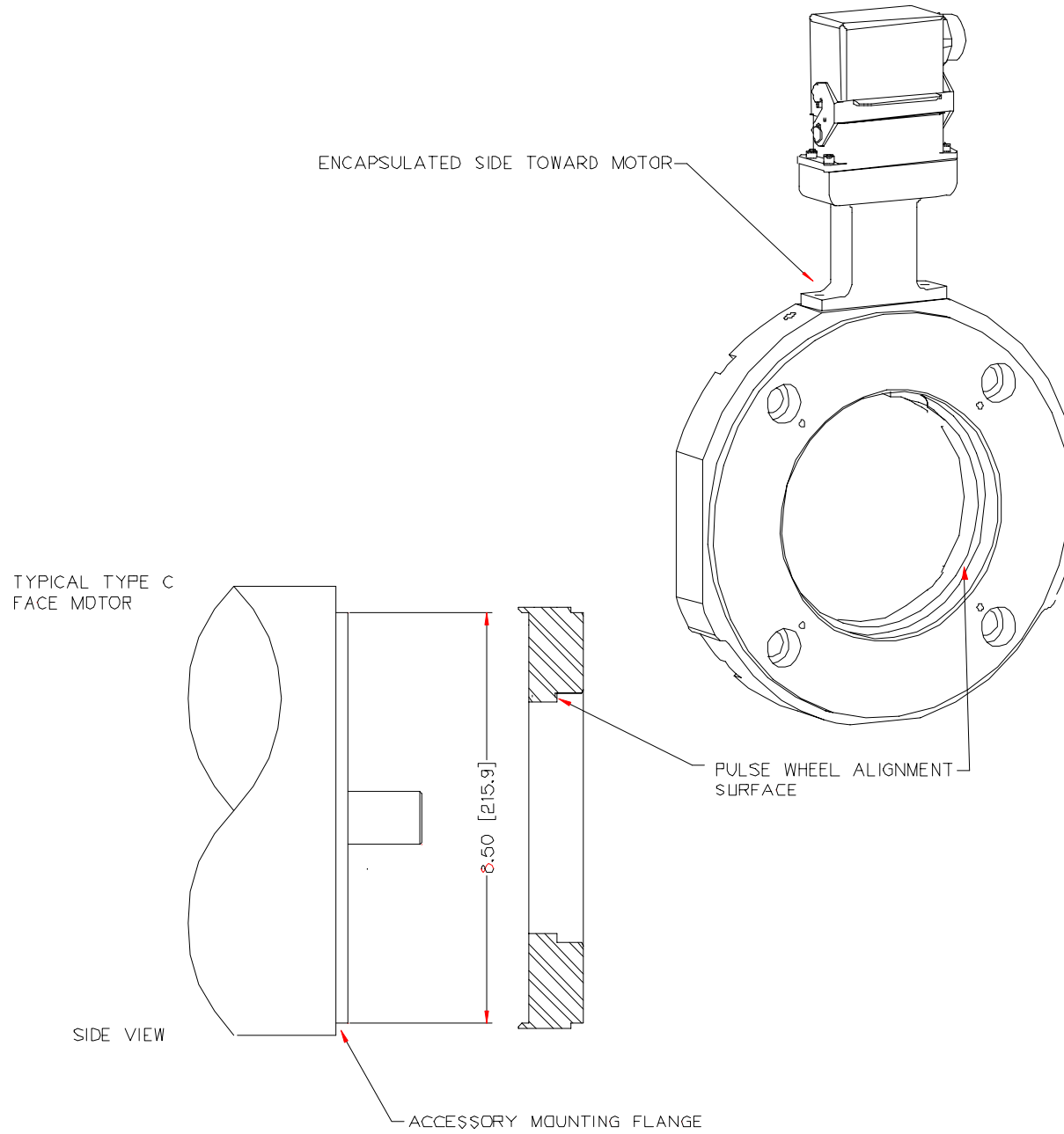

Figure 3: Typical Motor Mounting

2.1.2 Thru-Shaft Pulse Wheel Installation

1. Rotate the pulsewheel so the stamped letter “Z” or “This Side Out” is visible, away from the motor. Slide the pulse wheel onto the motor shaft. Push the wheel along the shaft until the edge of the pulsewheel is flush with the machined recess in the encoder frame. See Figure 4. It is recommended to use a straight edge for this purpose. For best results, align the two surfaces to within ± 0.010 inch. The purpose of this step is to properly center the pulsewheel under the sensor.
 - a. Clamp Style
With the pulsewheel properly aligned, use a 9/64 inch hex wrench to tighten the #8 socket head cap screw in the pulsewheel clamp to a nominal 30 inch-pounds.
 - b. Set Screw Style
With the pulsewheel properly aligned, use a 9/64 inch hex wrench to tighten (2) 8-32 UNC set screws with nominal torque.
3. Be sure the wheel does not have excessive wobble greater than 0.010 inch. Rotate the motor shaft by hand. It should freely rotate and not touch the frame at any time. If everything is mechanically correct, the resulting sensor to pulsewheel air gap will be a nominal 0.019 inch.
4. Position the encoder cover over the mounted encoder frame. Insert and tighten four Phillips head screws. This completes the mechanical mounting of the unit.

NOTE

The picture below shows how to align the pulse wheel on the SL85. The pulse wheel is aligned the same way for both the End-Of-Shaft and Thru-Shaft models. Be sure the letter “Z” and “This Side Out” are visible on the face of the pulse wheel after installation.

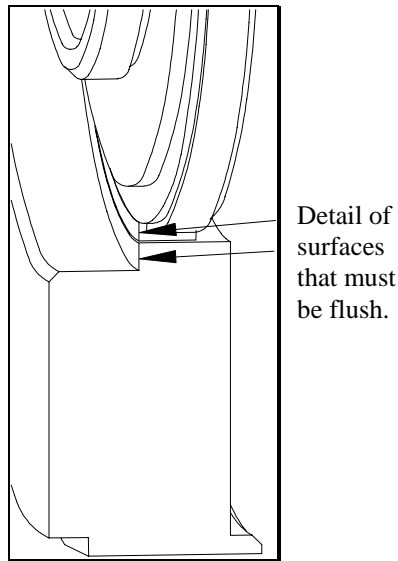
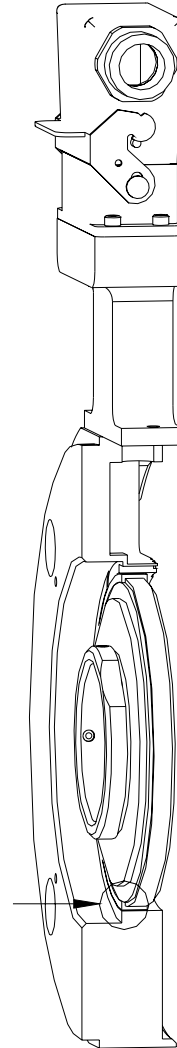

Figure 4: Pulse Wheel Orientation



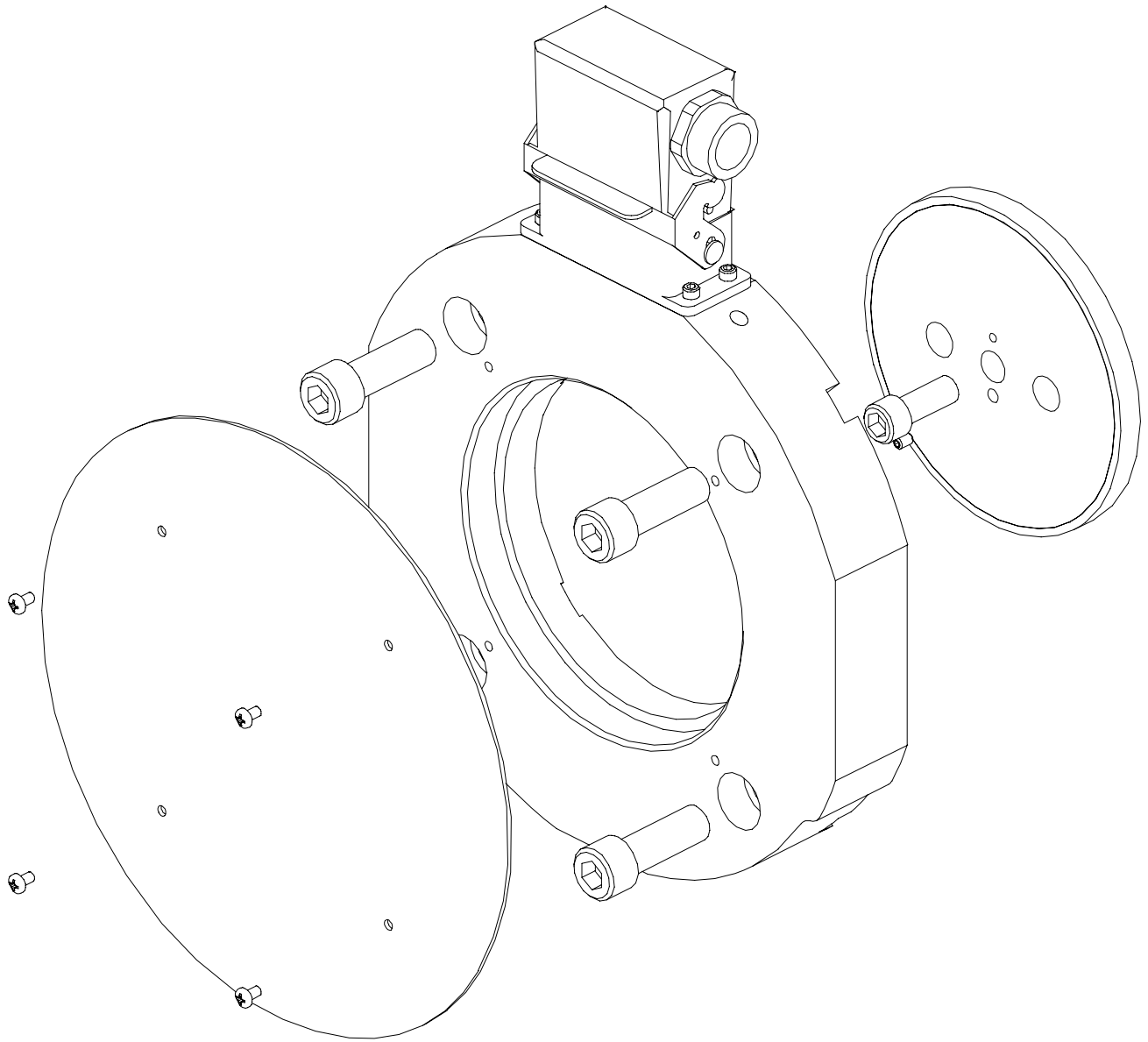

Figure 5: SLIM Tach® SL85 End-of-Shaft Exploded View

2.2 Motor Facing and Shaft for End-of-Shaft SL85

To prepare the motor facing and shaft for installation, perform the following steps. See Figure 6.

1. Clean outer rim and surface of motor facing and shaft of paint, grease, dirt, and other debris where SLIM Tach® SL85 unit contacts motor or accessory. Also ensure that mating surfaces have not been damaged and that unit will fit squarely on motor.
2. Apply a thin layer of corrosion preventative or oil to motor facing and shaft to aid assembly and provide some corrosion protection.

NOTE

Ensure there is no paint, burrs, protrusions, or deformations on the motor facing or shaft. If the enclosure does not fit squarely on the motor facing, the alignment between the sensor module and the magnetic pulse wheel may be degraded.

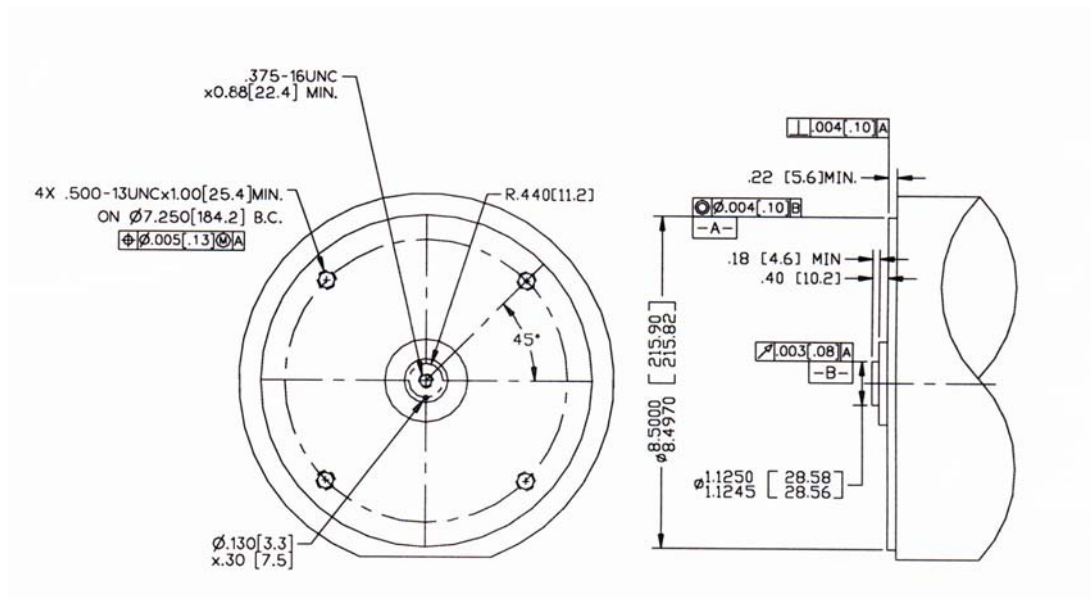

Figure 6: Typical 8.5-Inch Diameter Type C Face Motor End-Of-Shaft Application

2.2.1 Encoder Frame Installation: see page 8

2.2.2 End-of-Shaft Pulse Wheel Installation

To prepare the pulse wheel assembly for installation, perform the following steps. See Figure 7 .

CAUTION!

Caution must be used when handling the pulse wheel assembly. The surface of the pulse wheel outer rim is sensitive to scratches and impacts. The magnetic properties of the pulse wheel material can also be distorted or erased by exposure to strong magnetic fields.

1. Remove pulse wheel assembly from packaging.
2. Place one spacer washer into the shaft recess of the pulse wheel.

NOTE

The pulse wheel is designed to use one spacer washer for a motor shaft length of 0.400 ±0.010 inch. If the motor shaft is a different length, please refer to page 14 for axial adjustment procedure.

- Place pulse wheel shaft recess over the end of the motor shaft. Rotate the wheel so that the mounting bolt holes line up with the shaft tapped holes. Press the wheel assembly onto the shaft until it seats. Light tapping on the steel hub may be required.

NOTE

Some motor shafts do not have anti-rotation mounting holes. Instead, they have only one center tapped hole. For these cases, please review the Non-Standard End-of-Shaft Mounting Procedure on page 12.

- Insert and snug mounting bolts into the wheel. If the pulse wheel has not already seated, alternate tightening each bolt until it is seated. (E01 Pulse Wheel [1.125 inch shaft] units require only one center mounting bolt. After complete tightening the pulse wheel, tighten the 10-32 anti-rotation set screw.)
- Tighten each bolt to the proper torque: 15 foot-pounds for 10-24 bolts, and 30 foot-pounds for 3/8-16 bolts.

CAUTION!

The pulse wheel should be seated flat against the motor shaft. The wheel should not appear to wobble if the motor shaft is turned by hand. Excessive wobble (0.020" TIR) can damage the pulse wheel and sensor modules.

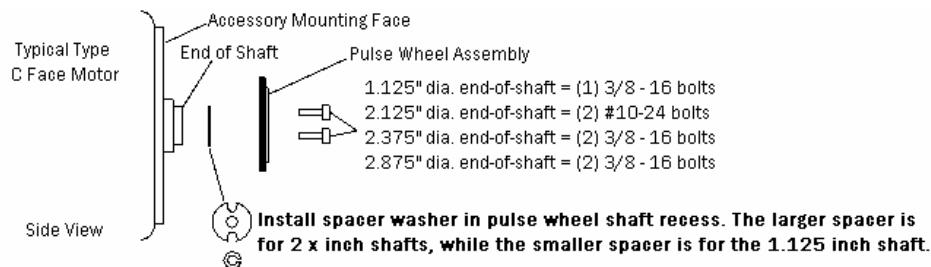

Figure 7: Pulse Wheel Assembly

2.3 Electrical Installation

Electrical connections are made to the sensor module through a standard 1/2 inch NPT liquid tight flexible conduit. The nipple length may be changed to extend the outlet box if desired. Interconnection cable recommendations are as follows: stranded copper, 22 through 16 gage, braided or foil with drain wire shielding 0.05 µF maximum total mutual or direct capacitance, outer sheath insulated. Shrink tubing may be placed over any wires without insulation. For lengths over 100 feet, use 18 gage or larger, to a maximum of 1000 feet. If shielded twisted pair wire is used, do not cross channels. Keep each pair of complementary channel outputs together in a single twisted pair (e.g., A and A complement).

CAUTION!

Reversing power and common will not damage the unit. However, applying power to any of the sensor outputs may cause damage.

Table 1. Signal Coding Table

| Signal | Connector Pin | Pigtail Cable | MS 3102E18-IT# |
|----------------|---------------|---------------|----------------|
| Common | 1 | Black | F |
| B | 2 | Green | B |
| A | 3 | Blue | A |
| Z * | 4 | Violet | C |
| No Connection | 5 | ----- | E |
| Vcc (5-15 VDC) | 6 | Red | D |
| /B | 7 | Yellow | I |
| /A | 8 | Gray | H |
| /Z * | 9 | Orange | J |
| Shield | 10 | Braid | G |

* Applies only to units with index pulse capability.
 # Pinouts are for the sensors with the MS 3102E18IT connector

NOTE

The shield in the sensor module is isolated from the frame of the encoder. For maximum noise immunity, the shield wire or pin should be connected to the shield of the cable and that of the drive or other receiving device.

2.3.1 Quick Release Connector Hood Wiring

To install the Quick Release Connector, perform the following steps.

1. Remove the four screws from the mating connector housing that hold the terminal block in place. Remove terminal block from housing.
2. Insert wiring through liquid tight flexible seal and mating connector housing. Leave enough wire exposed to comfortably reach the terminal block. Wire to terminal block according to wire code in Table 1. A similar wiring list is attached to enclosure.

NOTE

There are two orientations of the connector hood. The terminal block can be inserted either way so the connector hood points up or down. Choose the direction best for your application.

4. Tighten Liquid Tight fitting on housing. **OPTIONAL:** In some hostile environments, seal between connector body and Sensor Module can be improved by smearing a sealant (silicone grease, etc.) on the neoprene seal of the connector.
5. Mate connector into place on sensor mount and snap the two latches into place. If only one sensor is being installed, ensure cover plate is installed over other sensor hole.

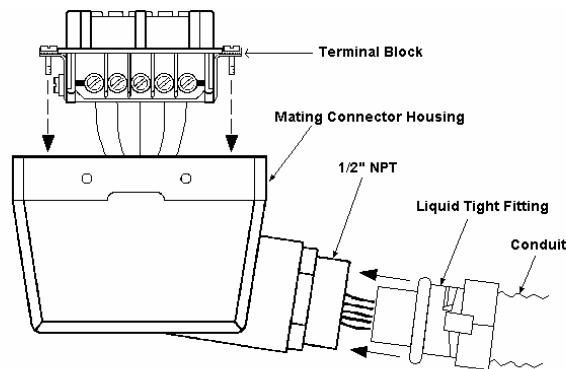

Figure 8: Sealed Industrial Latching Connector

2.3.2 Returning Equipment to Dynapar

If it is necessary to return the unit for repair or replacement, a Return Goods Authorization (RGA) number must be obtained from a factory representative before returning the equipment to our service department. When returning an instrument for service, the following information must be provided before Dynapar can attempt any repair.

1. Instrument model and serial number
2. User's name, company, address, and phone number
3. Malfunction symptoms
4. Description of system
5. Returned Goods Authorization number

Consult the factory for shipping instructions.



1675 Delany Road * Gurnee, IL * 60031 * USA

Customer Service:

Tel.: +1.800.873.8731

Fax: +1.847.662.4150

northstar.custserv@dancon.com

Technical Support

Tel.: +1.800.234.8731

Fax: +1.847.782.5277

northstar.techsupport@dancon.com

Website: www.dynapar.com