

NorthStar brand

Instruction Manual

SLIM Tach^o RL67 Magneto-resistive Encoder

Designed for use in
0.625" to 1.125" Thru-Shaft Diameter Applications



Danaher Controls

1675 Delany Road

Gurnee, IL 60031

Ph: 847-662-2666

Fax: 847-662-6633

www.NorthStarEncoders.com

791-1009-00

Table of Contents

Chapter/Paragraph/Illustration	Page
1 Introduction.....	4
1.0 Safety Summary.....	4
1.1 General.....	5
1.2 Description	5
<i>Figure 1: RIM Tach® RL67 Exploded View.....</i>	5
<i>Figure 2: RIM Tach® RL67 Dimensional Drawing</i>	6
1.3 Specifications	5
2 Installation.....	6
2.0 Inspection and Unpacking	6
2.1 Motor Facing and Shaft.....	7
<i>Figure 3: Typical 6.75 Inch Diameter Motor Facing or 4.5 Inch Type 56C -Face</i>	7
2.2 Tachometer Frame Installation	8
<i>Figure 4: Typical Motor Mounting</i>	8
<i>Figure 5: Pulse Wheel.....</i>	8
2.3 Electrical Installation	9
2.4 Quick Release Connector Hood Wiring.....	9
<i>Figure 6: Sealed Industrial Catching Connector.....</i>	10
2.5 Returning Equipment to NorthStar Technologies	10

Methods and apparatus disclosed and described herein have been developed solely on company funds of Danaher Controls No government or other contractual support or relationship whatsoever has existed which in any way affects or mitigates proprietary rights of Danaher Controls in these developments. Methods and apparatus disclosed herein may be subject to U.S. Patents existing or applied for. Danaher Controls reserves the right to add, improve, modify, or withdraw functions, design modifications, or products at any time without notice. We shall not be liable for errors contained herein or for incidental or consequential damages in connection with furnishing, performance, or use of this material.

CHAPTER 1 INTRODUCTION

1.0 Safety Summary

High current, voltage, and rotating parts can cause serious or fatal injury. The use of electric machinery, like all other uses of concentrated power and rotating equipment, may be hazardous. Installing, operating, and maintaining electric machinery should be performed by qualified personnel, in accordance with applicable provisions of the National Electrical Code and sound local practices. Failure to comply with these precautions or with specific warnings elsewhere in this manual violates safety standards of design, manufacture, and intended use of the instrument. Danaher Controls assumes no liability for the customer's failure to comply with these requirements.

Rotating Machinery

Avoid contact with rotating parts. Avoid by-passing or rendering inoperative any safety guards or protection devices. Avoid extended exposure in close proximity to machinery with high noise levels. Use proper care and procedures in handling, lifting, installing, operating and maintaining the equipment.

Before Installation

Safe maintenance practices with qualified personnel is imperative. Before starting maintenance procedures, be positive that, (1) equipment connected to the shaft will not cause mechanical rotation, (2) main machine windings have been disconnected and secured from all electrical power sources, and (3) all accessory devices associated with the work area have been de-energized. If high potential insulation test is required, follow procedures and precautions outlined in NEMA standards MG-1.

Grounding

Improperly grounding the frame of the machine can cause serious or fatal injury to personnel. Grounding of the machine frame and structure should comply with the National Electrical Code and with sound local practices. Check wiring diagram before connecting power.

Do Not Operate In An Explosive Atmosphere

Do not operate the instrument in the presence of flammable gases or fumes. Operating any electrical instrument in such an environment constitutes a definite safety hazard.

Keep Away From Live Circuits

Operating personnel must not remove instrument covers. Component replacement and internal adjustments must be made by qualified maintenance personnel. Do not replace components with power cable connected. To avoid injuries, always disconnect power and discharge circuits before touching them.

Do Not Substitute Parts Or Modify Instrument

Do not install substitute parts or perform any unauthorized modification to the instrument. Introducing additional hazards is dangerous. Return the instrument to an authorized Danaher Controls representative for service and repair to ensure that safety features are maintained.



CAUTION!: Crucial information, that *must* be read and followed, regarding safety and unit functioning.



DO THIS!: Additional procedure, that must be read and followed, without safety issues.



NOTE: Useful information that should be read.



QUESTION: Helpful hints to answer your possible questions.

1.1 General

These instructions do not claim to cover all details of variation in equipment or to provide for every possible contingency or hazard to be met in connection with installation, operation, and service.

1.2 Description

The NorthStar SLIM Tach® RL67 is a modular digital tachometer. This magneto-resistive encoder sensor-based unit was designed specifically for Reliance motors. The tachometer frame is mounted onto the 6.75 inch recess on the Reliance motor. This positions the sensor and contains the electronics. The magnetic pulse wheel on the motor shaft has magnetic pulses imprinted on its outside surface. As the motor spins, the passing magnetic pulses actuate the magneto-resistive sensor. The resulting electronic signals are processed into square wave signals by the internal electronics.

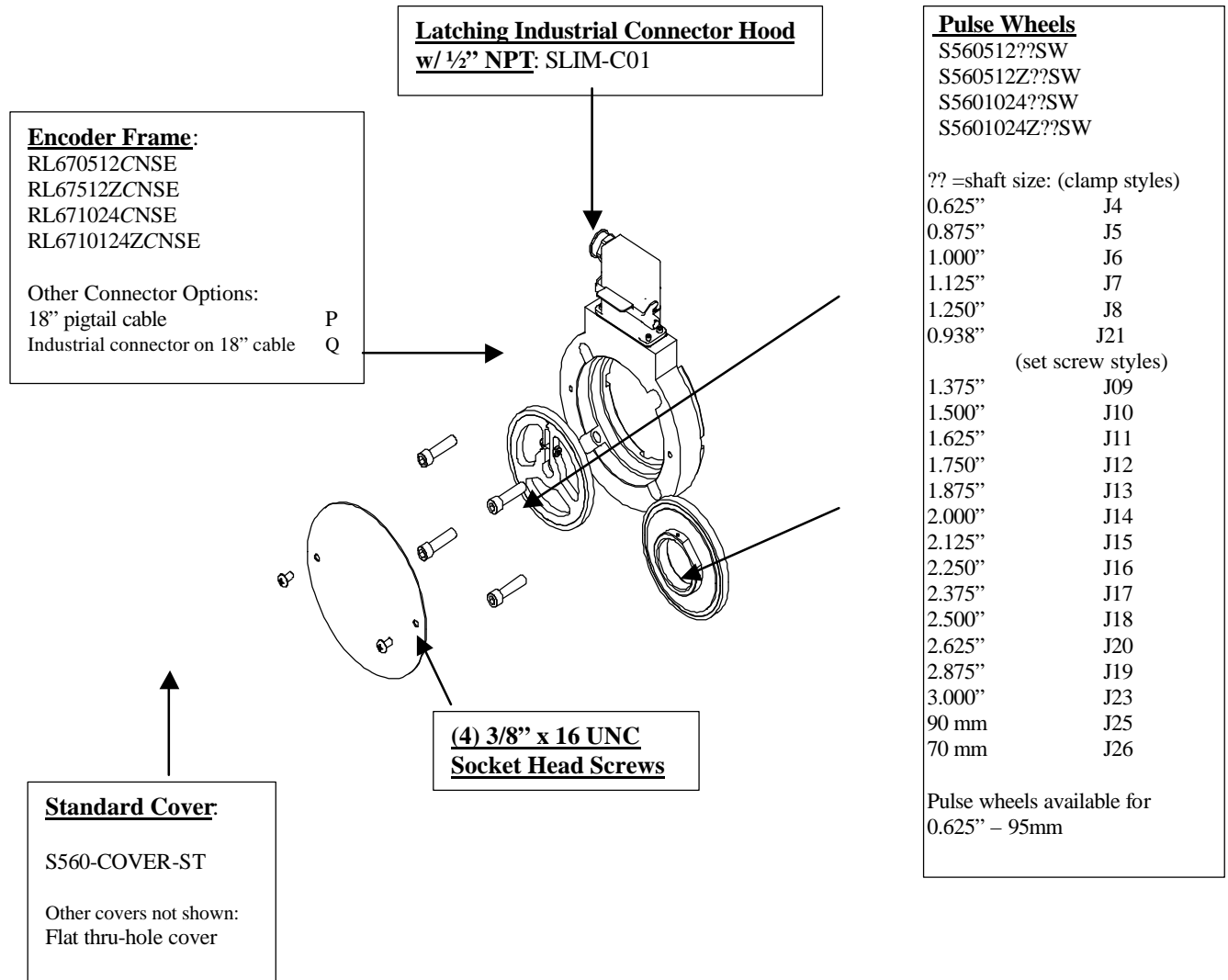

Figure 1: RIM Tach RL67 Exploded View

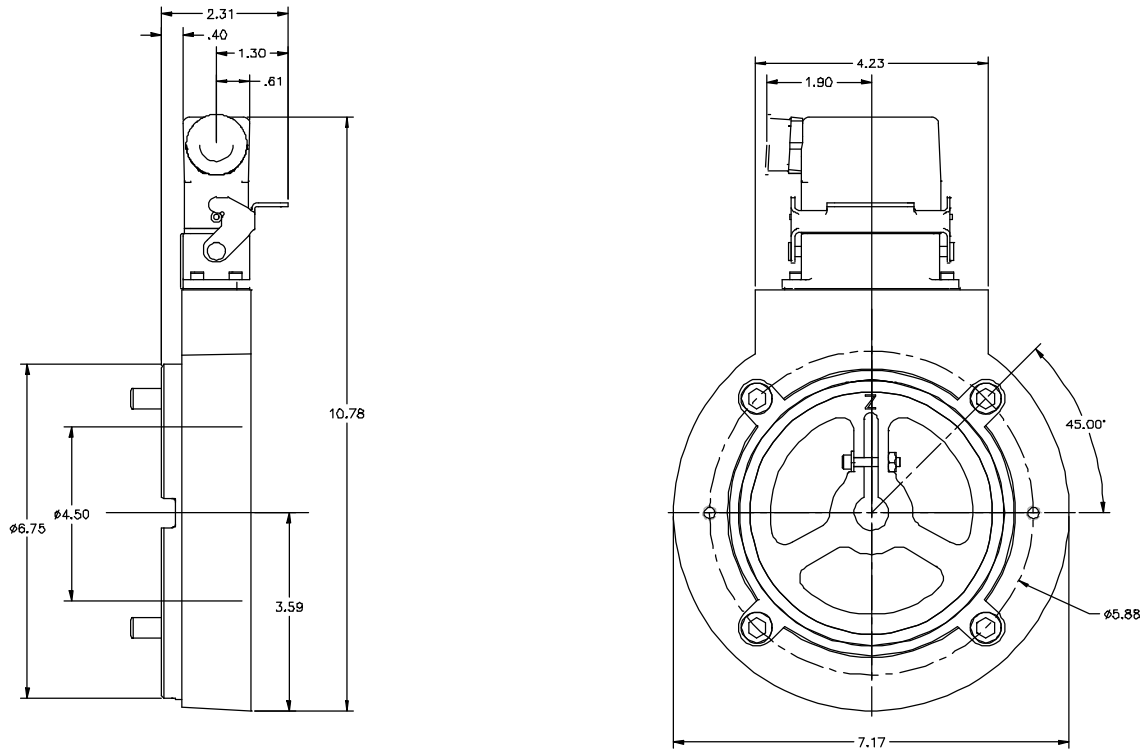

Figure 2: RIM Tach RL67 Dimensional Drawing

1.3 Specifications (subject to change without notice)

Electrical Specifications	
Resolution	512, 512Z, 1024, 1024Z PPR
Frequency Response	Minimum 120 kHz
Pulse Code	A, B, Z (Index), and complements (A, B, Z)
Output Phases	A phase, B phase: 90° phase gap; Z phase: Once per revolution
Pulse Duty Cycle	50 ± 15% (within defined mechanical specs)
Quadratic Accuracy	90° ± 22°
Output Type	High Speed, Differential Driver
Rise and Fall	Less than 500 Ns @ 10,000 pf (typical)
Current Consumption	35 mA typical plus line driver load
ESD Protection	2 kV
Output Current Capability	145 mA typical [400 mA maximum (worst case)]
Cable	22 AWG, 8 conductor, 18 inch length individually shielded, twisted pair
Input Voltage	+5.0 to +15.0 VDC
Mechanical Specifications	
Maximum Operational Speed	6,000 RPM (120 kHz)
Nominal Air Gap	0.019 inch ± 0.008 inch
Shaft Axial End Play	Up to ± 0.045 inch maximum
Enclosure Configuration	6.75" diameter Reliance mating face
Acceleration Rate	12,000 RPM per second
Unit Weight / Dimensions	3 lbs. / 9.0" (229mm) x 9.0" (229mm) x 4.0" (102mm)
Boxed Weight / Dimensions	4 lbs. / 14.5" (370mm) x 9.5" (242mm) x 4.5" (115mm)
Common Environmental Specifications	
Operational Temperature	-40° to + 90° C
Operational Humidity Range	Minimum of 90%
Chemical Resistance	Salt Spray, Most Solvents, Mild Acids and Bases
Vibration	Minimum 18 g's RMS, 5-2000 Hz
Shock (Encoder Housing)	1 meter drop tested, min 30 g's shock spectrum

CHAPTER 2 INSTALLATION

2.0 Inspection and Unpacking

Inspect shipping container for external damage. All claims for damage (apparent or concealed) or partial loss of shipment must be made in writing to NorthStar within (5) days from receipt of goods. If damage or loss is apparent, please notify the shipping agent immediately.

Open shipping container and locate the packing list. The packing list is included to simplify checking that all components, accessories, and manual were received. Please use the packing list to check off each item as the unit is unpacked. Inspect for damage. NorthStar recommends that the shipping container be retained for future shipping, storage, or return to factory purposes.

If any equipment is damaged in transit, be sure to file proper claims promptly with the carrier and insurance company. Please advise NorthStar Technologies of such filing. In case of parts shortages, advise NorthStar immediately. NorthStar cannot be responsible for any missing parts unless notified within 60 days of shipment.

2.1 Motor Facing and Shaft

To prepare the motor facing and shaft for installation: (see Figure 3)

1. Clean outer rim and surface of motor facing and shaft of paint, grease, dirt, and other debris where SLIM Tach[®] RL67 unit contacts motor or accessory. Also ensure that mating surfaces have not been damaged and that unit will fit squarely on motor.
2. Apply a thin layer of corrosion preventative or oil to motor facing and shaft to aid assembly and provide some corrosion protection.



Ensure there is no paint, burrs, protrusions, or deformations on the motor facing or shaft. If the enclosure does not fit squarely on the motor facing, the alignment between the sensor module and the magnetic pulse wheel may be degraded.

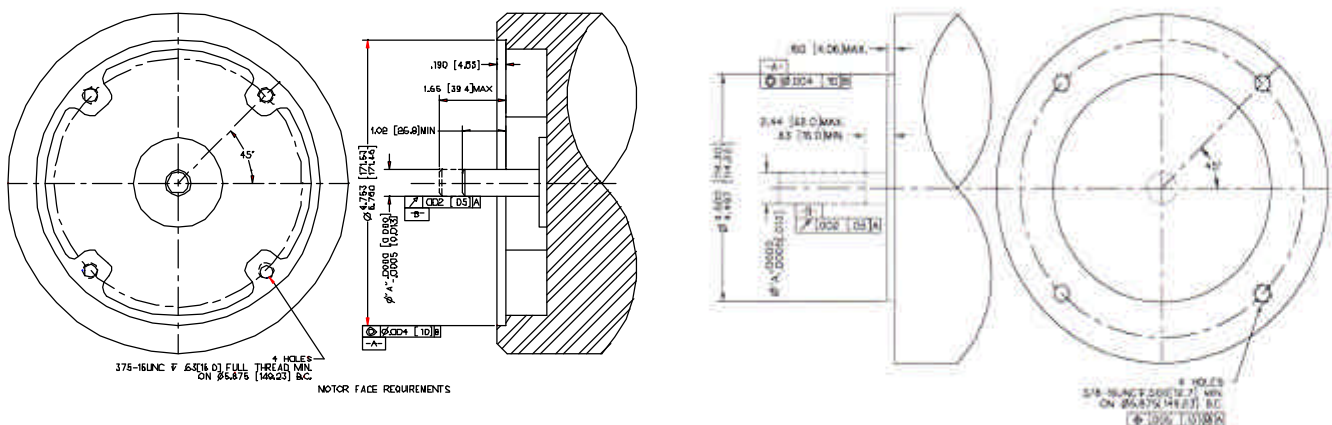

Figure 3. Typical 6.75 Inch Diameter Motor Facing (left) or 4.5 Inch Type 56C- Face (right)

2.2 Tachometer Frame Installation

To install the tachometer frame: (see Figure 4)

1. Orient the tachometer frame so the 4.5 inch I.D. surface will fit over the 4.5 inch C flange (encapsulated side toward the motor). Mount frame onto the motor flange. Insert the through the frame and into the motor frame. Use a 5/16 inch hex wrench to tighten a nominal 25 foot pounds.

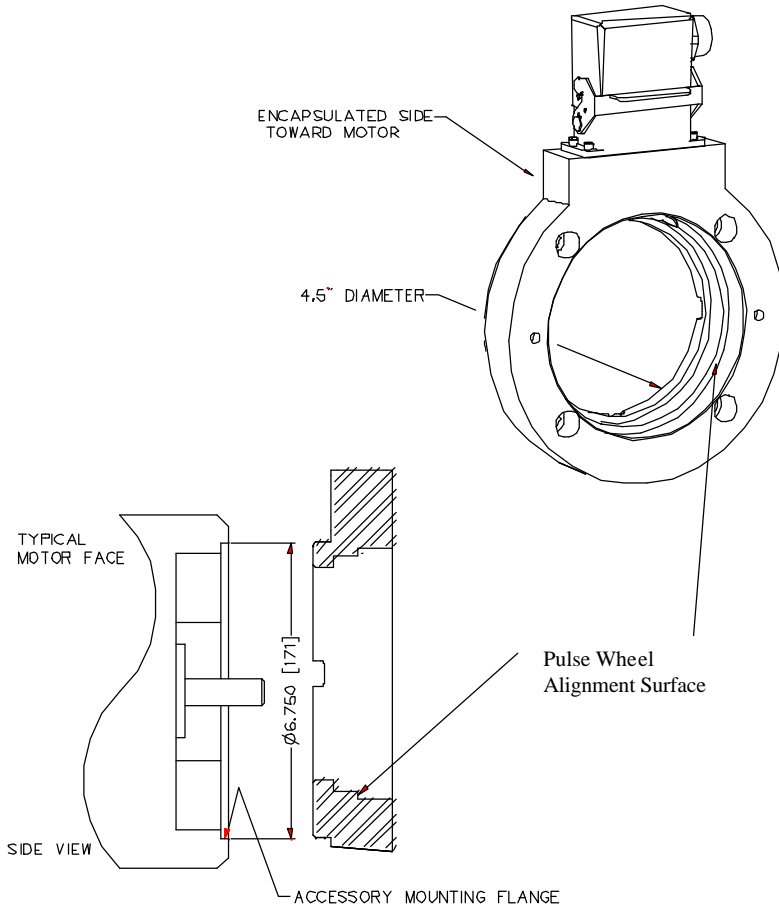

Figure 4: Typical Motor Mounting

2. Rotate the pulse wheel so the words "THIS SIDE OUT" (or stamped letter "Z") is visible, away from the motor. Slide the pulse wheel onto the motor shaft. Push the wheel along the shaft until the edge of the pulse wheel is flush with the machined recess in the tachometer frame (see Figure 4). The purpose of this step is to properly center the pulse wheel under the sensor.



We recommend you use a straight edge for this purpose. For best results, align the two surfaces to within ± 0.010 inch.

3. With the pulse wheel properly aligned, use a 9/64 inch hex wrench to tighten the #8 socket head cap screw in the pulse wheel clamp to a nominal 5 foot-pounds. Be sure the wheel does not have excessive wobble greater than 0.010 inch. Rotate the motor shaft by hand. It should freely rotate and not touch the frame at any time. If everything is mechanically correct, the resulting sensor to pulse wheel air gap to the frame will be a nominal 0.006 inch.

4. Position the tachometer cover over the mounted encoder frame. Insert and tighten two Phillips head screws. This completes the mechanical mounting of the unit.

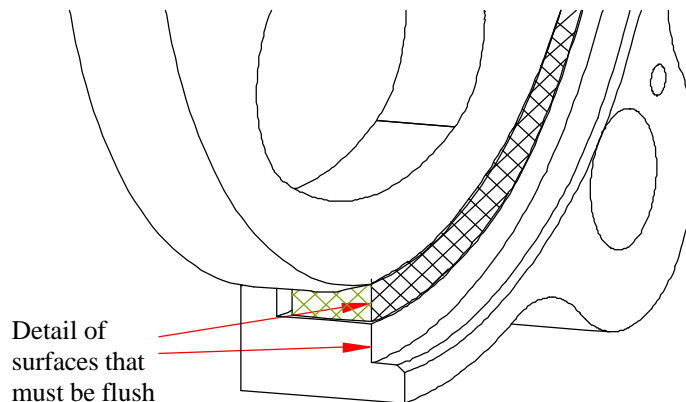

Figure 5: Pulse Wheel

2.3 Electrical Installation

Electrical connections are made to the sensor module through a standard 1/2 inch NPT liquid tight flexible conduit. The nipple length may be changed to extend the outlet box if desired. Interconnection cable recommendations are as follows: stranded copper, 22 through 16 gage, braided or foil with drain wire shielding 0.05 µF maximum total mutual or direct capacitance, outer sheath insulated. Shrink tubing may be placed over any wires without insulation. For lengths over 100 feet, use 18 gage or larger, to a maximum of 1000 feet. If shielded twisted pair wire is used, do not cross channels. Keep each pair of complementary channel outputs together in a single twisted pair (e.g., A and A complement).



Reversing power and common will not damage the unit. However, applying power to any of the sensor outputs may cause damage.

Signal	Connector Pin	Pigtail Cable	MS 3102E18-IT#
Common	1	Black	F
B	2	Green	B
A	3	Blue	A
Z *	4	Violet	C
No Connection	5	-----	E
Vcc (5-15 VDC)	6	Red	D
/B	7	Yellow	I
/A	8	Gray	H
/Z *	9	Orange	J
Shield	10	Braid	G

* Applies only to units with index pulse capability.

Pinouts are for the sensors with the MS 3102E18IT connector



The shield in the sensor module is isolated from the frame of the encoder for maximum noise immunity. The shield wire or pin should be connected to the shield of the cable and that of the drive or other receiving device.

2.4 Quick Release Connector Hood Wiring

To install the Quick Release Connector:

1. Remove the four screws from the mating connector housing that hold the terminal block in place. Remove terminal block from housing.
2. Insert wiring through liquid tight flexible seal and mating connector housing. Leave enough wire exposed to comfortably reach the terminal block. Wire to terminal block according to wire code in Table 1. A similar wiring list is attached to enclosure.



There are two orientations of the connector hood. The terminal block can be inserted either way so the connector hood points up or down. Choose the direction best for your application.

4. Tighten Liquid Tight fitting on housing. **OPTIONAL:** In some hostile environments, seal between connector body and Sensor Module can be improved by smearing a sealant (silicone grease, etc.) on the neoprene seal of the connector.
5. Mate connector into place on sensor mount and snap the two latches into place. If only one sensor is being installed, ensure cover plate is installed over other sensor hole.

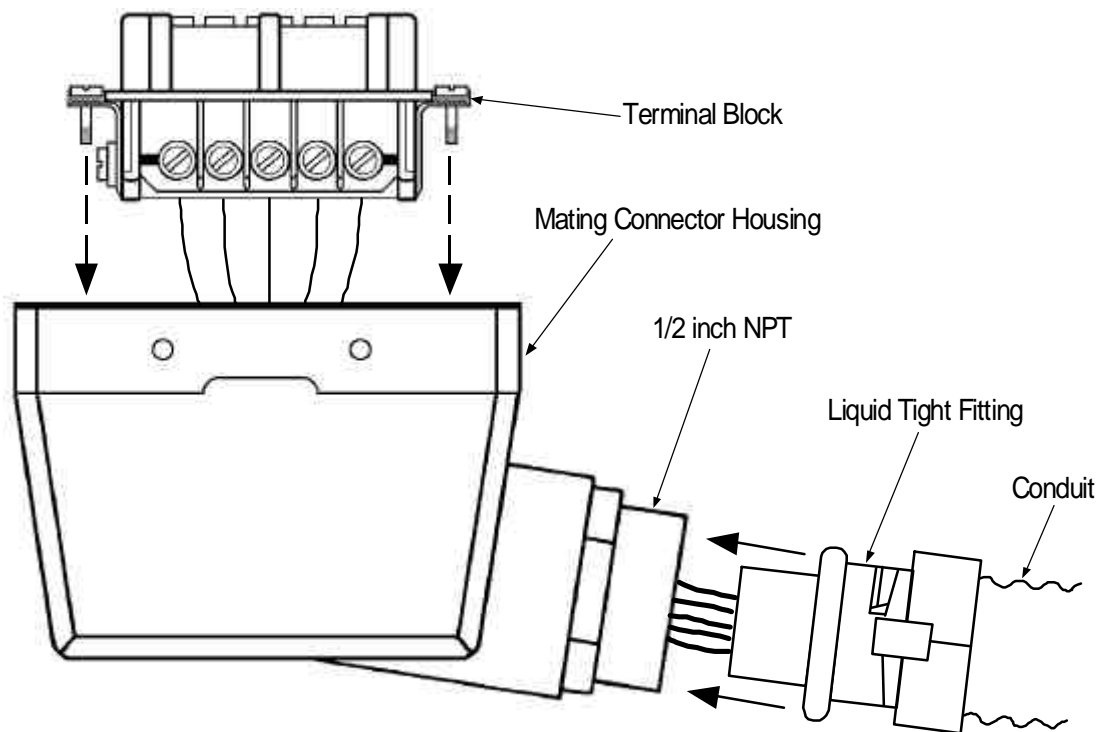

Figure 6: Sealed Industrial Latching Connector

2.5 Returning Equipment to Danaher Controls

If it is necessary to return the unit for repair or replacement, a Return Goods Authorization (RGA) number must be obtained from a factory representative before returning the equipment to our service department. When returning an instrument for service, the following information must be provided before we can attempt any repair.

1. Instrument model and serial number
2. User's name, company, address, and phone number
3. Malfunction symptoms
4. Description of system
5. Returned Goods Authorization number

Consult the factory for shipping instructions.