

NorthStar brand

Instruction Manual

RIM Tach[®] 8500 & 8500 Quad Digital Tachometer

Designed for use in
**0.625" to 4.500" Outer Diameter
Thru-Shaft Applications**



Danaher Controls

1675 Delany Road
Gurnee, IL 60031
Ph: 847-662-2666
Fax: 847-662-6633

www.NorthStarEncoders.com

791-1001-00

Table of Contents

Chapter/Paragraph/Illustration	Page
1 Introduction	4
1.0 Safety Summary	4
1.1 General	5
1.2 Description	5
<i>Figure 1: RIM Tach Thru-Shaft Enclosure/Sensor Physical Dimension</i>	5
<i>Figure 2: RIM Tach 8500 Thru-Shaft Exploded View w/ Spare Parts</i>	6
<i>Figure 3: RIM Tach 8500 Mounting Tolerances</i>	6
1.3 Specifications	7
2 Installation	8
2.0 Inspection and Unpacking	8
2.1 Painting Considerations	8
2.2 Mechanical Installation	8
2.2.1 Motor Facing and Shaft	8
<i>Figure 4: Typical 8.5 Inch Diameter Type C-Face</i>	9
2.2.2 Pulse Wheel Assembly	9
<i>Figure 5: Pulse Wheel Assembly</i>	10
2.2.3 High Slew Rate Wheels	10
<i>Figure 6: High Slew Rate Wheel</i>	11
2.2.4 Pulse Wheel Assembly Axial Position Adjustment	11
<i>Figure 7: Pulse Wheel Alignment Check Using Straight Edge</i>	12
2.2.5 Enclosure Installation	12
<i>Figure 8: Enclosure Installation</i>	12
2.2.6 Optional Pulse Wheel Alignment Check	13
<i>Figure 9: Optional Pulse Wheel Alignment Check With Depth Gauge</i>	13
2.2.7 Sensor Module(s) Installation	13
<i>Figure 10: Sensor Module(s) Installation</i>	14
2.3 Electrical Installation	14
2.3.1 Quick Release Connector Hood Wiring	15

Methods and apparatus disclosed and described herein have been developed solely on company funds of Danaher Controls No government or other contractual support or relationship whatsoever has existed which in any way affects or mitigates proprietary rights of Danaher Controls in these developments. Methods and apparatus disclosed herein may be subject to U.S. Patents existing or applied for. Danaher Controls reserves the right to add, improve, modify, or withdraw functions, design modifications, or products at any time without notice. Danaher Controls shall not be liable for errors contained herein or for incidental or consequential damages in connection with furnishing, performance, or use of this material.

CHAPTER 1 INTRODUCTION

1.0 Safety Summary

High current, voltage, and rotating parts can cause serious or fatal injury. The use of electric machinery, like all other uses of concentrated power and rotating equipment, may be hazardous. Installing, operating, and maintaining electric machinery should be performed by qualified personnel, in accordance with applicable provisions of the National Electrical Code and sound local practices. Failure to comply with these precautions or with specific warnings elsewhere in this manual violates safety standards of design, manufacture, and intended use of the instrument. Danaher Controls assumes no liability for the customer's failure to comply with these requirements.

Rotating Machinery

Avoid contact with rotating parts. Avoid by-passing or rendering inoperative any safety guards or protection devices. Avoid extended exposure in close proximity to machinery with high noise levels. Use proper care and procedures in handling, lifting, installing, operating and maintaining the equipment.

Before Installation

Safe maintenance practices with qualified personnel is imperative. Before starting maintenance procedures, be positive that, (1) equipment connected to the shaft will not cause mechanical rotation, (2) main machine windings have been disconnected and secured from all electrical power sources, and (3) all accessory devices associates with the work area have been de-energized. If high potential insulation test is required, follow procedures and precautions outlined in NEMA standards MG-1.

Grounding

Improperly grounding the frame of the machine can cause serious or fatal injury to personnel. Grounding of the machine frame and structure should comply with the National Electrical Code and with sound local practices. Check wiring diagram before connecting power.

Do Not Operate In An Explosive Atmosphere

Do not operate the instrument in the presence of flammable gases or fumes. Operating any electrical instrument in such an environment constitutes a definite safety hazard.

Keep Away From Live Circuits

Operating personnel must not remove instrument covers. Component replacement and internal adjustments must be made by qualified maintenance personnel. Do not replace components with power cable connected. To avoid injuries, always disconnect power and discharge circuits before touching them.

Do Not Substitute Parts Or Modify Instrument

Do not install substitute parts or perform any unauthorized modification to the instrument. Introducing additional hazards is dangerous. Return the instrument to an authorized Danaher Controls representative for service and repair to ensure that safety features are maintained.



CAUTION!: Crucial information, that *must* be read and followed regarding safety and unit functioning.



DO THIS!: Additional procedure, that must be read and followed, without safety issues.



NOTE: Useful information that should be read.



QUESTION: Helpful hints to answer your possible questions.

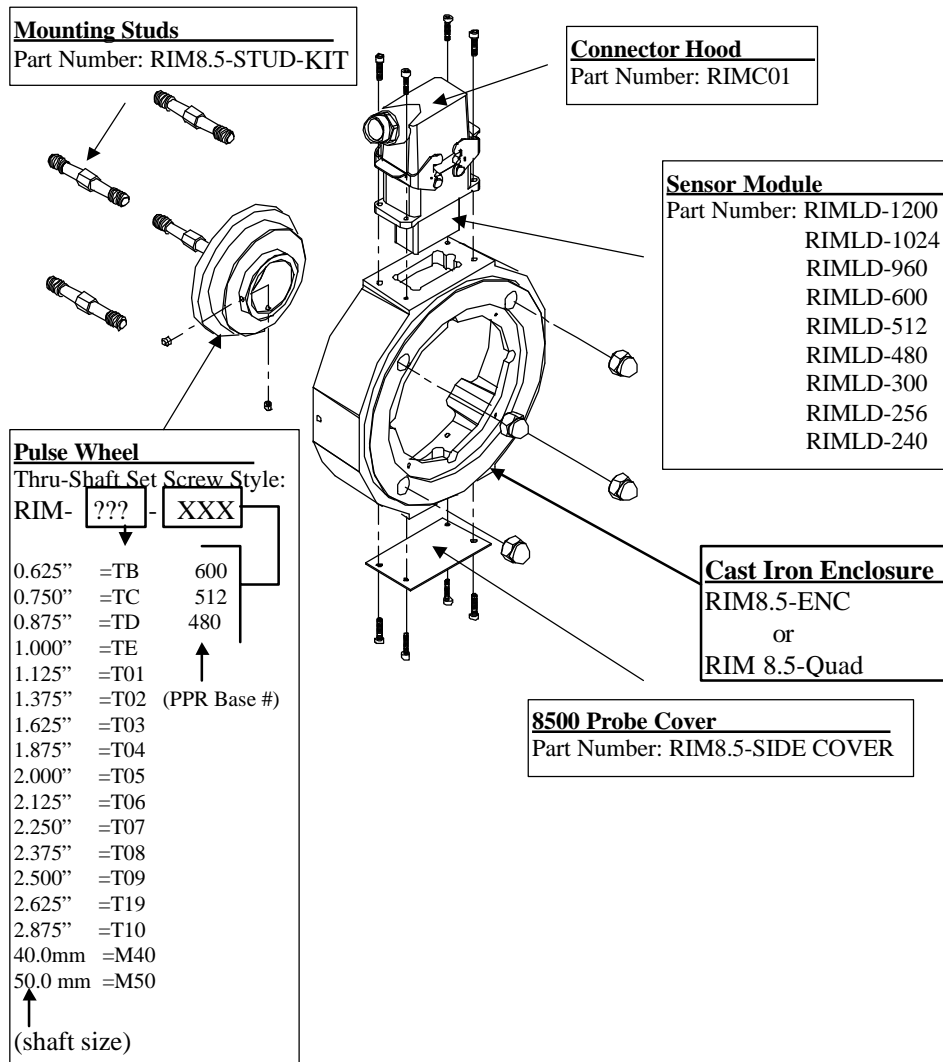

Figure 2: RIM Tach[®] 8500 Thru-Shaft Exploded View w/ Spare Parts

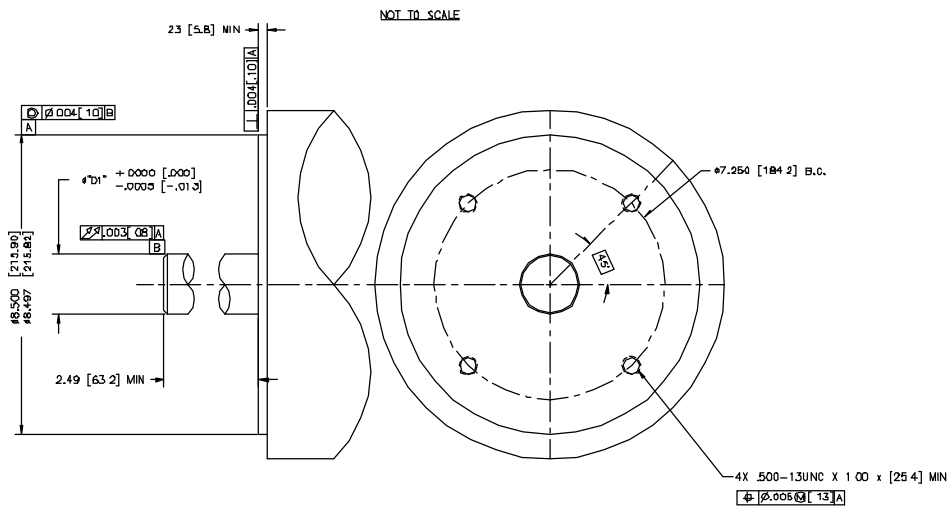

Figure 3: RIM Tach[®] 8500 Mounting Tolerances

1.3 Specifications

Electrical Specifications	
Frequency Response	0 - 120 kHz
Pulse Code	A, B, Z (Index), and complements (A, B, Z)
Output Phases	A phase, B phase @ quadrature 90°C, Z phase: One per rev (gated)
Pulse Duty Cycle	50 ± 15% (within defined mechanical specifications)
Quadrature Accuracy	90 ± 22° (within defined mechanical specifications)
Output Type	High speed, differential line driver,
Rise and Fall Time	Less than 1µs @ 10,000 pf typical load
Current Consumption	45 mA typical plus line driver load
Output Current	150 mA maximum continuous
ESD Protection	2 kV
Mechanical Specifications	
Maximum Operational Speed	7,000 RPM or 120 kHz
Shaft Axial End Play	Up to ± 0.050 inch
Enclosure Configuration	8.5" diameter 180 C motor face or accessory flange to meet NEMA MG1-4 standards
Acceleration Rate	3,600 RPM/second, 12,000 RPM (with optional high slew rate pulse wheel)
Enclosure Material	Ductile iron casting
Sensor Module Material	Stainless steel
Unit Weight / Dimensions	23 lbs. (10.5mm) / 8.5" (216mm) x 3.7" (95mm) x 8.96" (228mm)
Box Weight / Dimensions	1.5 lbs. (0.70mm) / 22" (560mm) x 12" (305mm) x 9" (230mm)
Environmental Specifications	
Operational Temperature	-40° to +80° C
Operational Humidity Capability	Maximum of 90%
Chemical Resistance	Salt spray, most solvents, mild acids and bases
Vibration	Minimum 18 g's RMS, 5-2000 Hz shock spectrum
Shock (Sensor Module)	1 meter drop tested, min. 30g's
Interface Specifications	
Power	+5.0 to +15.0 VDC
Output	Differential output swinging between Vcc - 0.6V and ground
Connector	10 pin industrial latching connector with 1/2inch NPT fitting, IP-65 NEMA 4,12 rated
Suggested Cable	22 - 16 AWG, 10 conductor, shielded, twisted pair

Specifications subject to change without notice.

CHAPTER 2 INSTALLATION

2.0 Inspection and Unpacking

Inspect shipping container for external damage. All claims for damage (apparent or concealed) or partial loss of shipment must be made in writing to Danaher Controls within (5) days from receipt of goods. If damage or loss is apparent, please notify the shipping agent immediately.

Open shipping container and locate the packing list. The packing list is included to verify that all components, accessories, and manual were received. Please use the packing list to check off each item as the unit is unpacked. Inspect for damage. Danaher Controls recommends that the shipping container be retained for future shipping, storage, or return to factory purposes.

If any equipment was damaged in transit, be sure to file proper claims promptly with the carrier and insurance company. Please advise Danaher Controls of such filing. In case of parts shortages, advise us immediately. We cannot be responsible for any missing parts unless notified within 60 days of shipment.

2.1 Painting Considerations

The enclosure may be painted. Please pay attention to the following considerations.



Corrosion preventative grease has been applied to the enclosure. Standard degreasing practices must be followed before applying paint.

- Do not hinder the latches on the connector if the connector is painted.
- If the enclosure is painted before the sensor module(s) is added, be sure to mask off the area where the sensor module(s) will be placed. The module must mate directly to the enclosure. Failure to do this will degrade the alignment of the system and may cause it to fail.

2.2 Mechanical Installation

2.2.1 Motor Facing and Shaft

The RIM Tach[®] 8500 has been designed to be mounted on a 8.5 inch diameter 180 C Flange that meets or exceeds the NEMA MG1-4 Standards. To prepare the motor facing and shaft for installation, perform the following steps (*see Figure 2*).

1. Clean outer rim and surface of motor facing and shaft of paint, grease, dirt and other debris where RIM Tach[®] 8500 unit contacts motor or accessory. Also ensure that mating surfaces have not been damaged and that unit will fit squarely on motor.

Ensure there is no paint, burrs, protrusions, or deformations on the motor facing or shaft. If the enclosure does not fit squarely on the motor facing, the alignment between the sensor module and the magnetic pulse wheel may be degraded.

2. Apply  a layer of corrosion preventative or oil to motor facing and shaft to aid assembly and provide some corrosion protection.



The pulse wheel must be well attached during rapid acceleration or deceleration of the shaft. The installer may elect to drill the set screw holes before installing the enclosure. Alternatively, the installer may elect to install the enclosure, measure, and then remove the enclosure before drilling. Continue with Steps 3 through 5 if electing to predrill set screw holes. If not, proceed to Section 2.2.2 and continue with the installation procedure. Drilling instructions will be provided again in Section 2.2.5.

- The pulse wheel assembly uses two set screws to hold the unit in place. These holes should be at 90 degrees to each other and located $2.316'' \pm 0.005$ from the motor facing.
- Use standard $\frac{1}{4}''$ bit to drill a hole approximately 0.1'' deep from the tangent point of the shaft (point of first contact of the drill to the shaft) to the bottom of the hole. Do this for both holes.

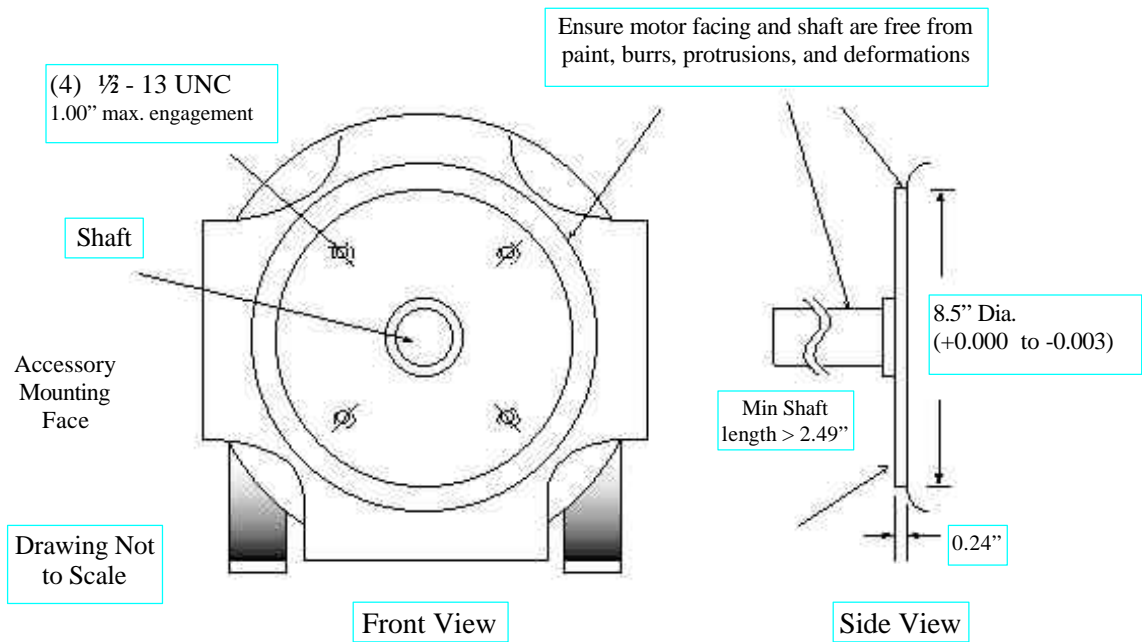

Figure 4: Typical 8.5" Diameter Type C-Face Motor

2.2.2 Pulse Wheel Assembly

To prepare the pulse wheel assembly for installation, perform the following steps (*see Figure 3*).



Caution must be used when handling the pulse wheel assembly. The surface of the pulse wheel outer rim is sensitive to scratches and impacts. The magnetic properties of the pulse wheel material can also be distorted or erased by exposure to strong magnetic fields.

- Remove pulse wheel assembly from packaging.
- Leave protective red rubber band in place over pulse wheel.
- Place assembly over the end of the shaft. The wheel side with the two set screws should be toward the outside, away from motor.



Be sure the set screws in the adapter are retracted so that they will not interfere with the shaft while mounting the unit.

- Slide assembly on the shaft until there is about a 1 inch gap left between inner face of pulse wheel and motor facing. It may be necessary to lightly tap the assembly to get it all the way on. The 1 inch gap is not a critical measurement.



Tap on the steel hub; not on the silver-colored aluminum magnetic wheel.

5. If set screw locating holes have already been drilled, align unit to holes and tighten set screws to a nominal 15 inch-pounds. If set screw locating holes will not be used or if they will be added using an alternate method, just leave assembly in place and continue to Section 2.5.

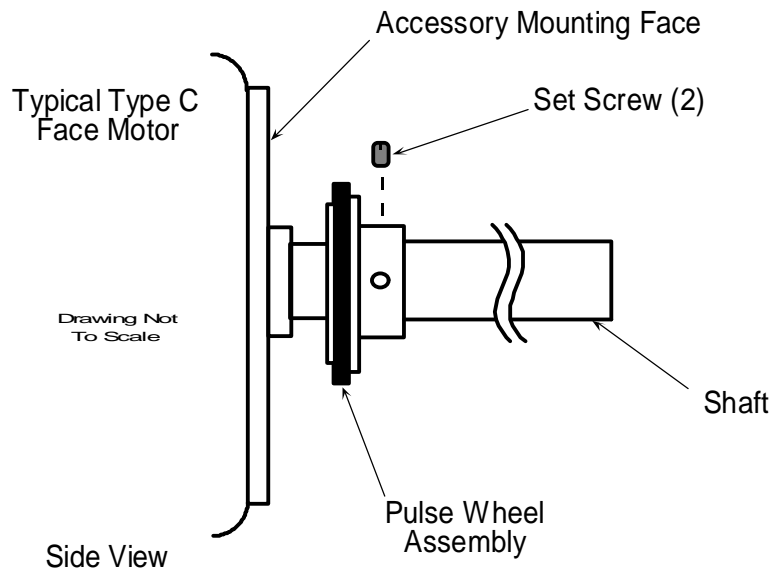

Figure 5: Pulse Wheel Assembly

2.2.3 High Slew Rate Wheels

The following section discusses how to mount a high slew rate wheel.

1. Loosen the screws around the outer portion of the wheel to approximately .030 inch gap. This will allow the inner diameter ring enough space to move out of the way of the shaft. Do not to open the gap too far or the ring will move out of the pocket it sits in.
2. Place the pulse wheel over the end of the shaft. The pulse wheel will stop at the ring. With a pen (or some other object that will not damage the shaft) work the ring around the shaft into the groove in the wheel. The wheel should then completely slide on the shaft.
3. Place the housing on the motor using the four 1/2-13 mounting studs. Bolt the housing down with the four 1/2-13 cap nuts. Align the pulse wheel so that it is flush with the alignment surface of the housing.
4. Finally, tighten down the pulse wheel mounting bolts in a star pattern.



NorthStar recommends that if a brake is going to be used in conjunction with the an encoder, the encoder must use a high slew rate wheel. NorthStar considers <3600 RPM per second acceleration or deceleration of the shaft to be a high slew rate wheel application.

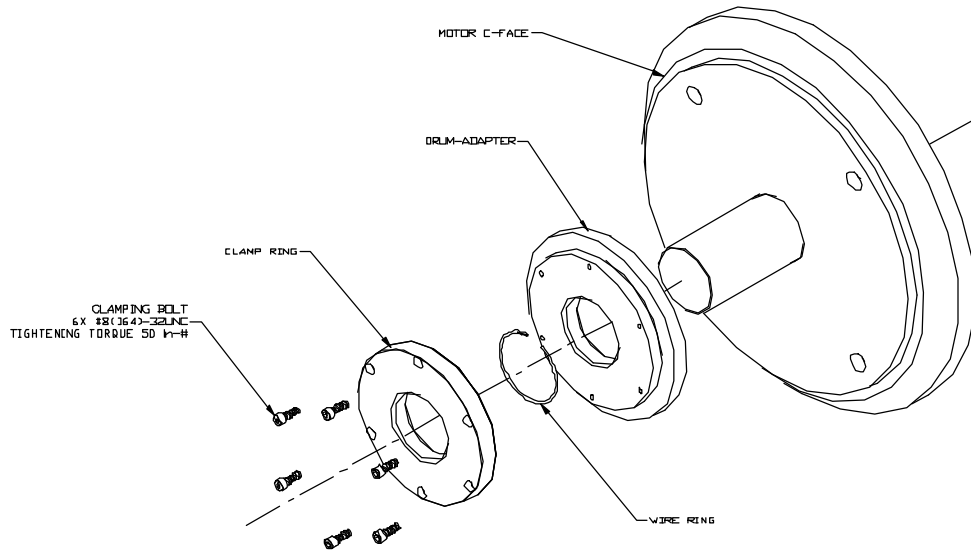

Figure 6: High Slew Rate Wheel

2.2.4 Pulse Wheel Assembly Axial Position Adjustment

If the pulse wheel is not lined up and no pre-drilled holes are required, use the following procedure to adjust the position of the pulse wheel assembly (see Figure 4-6).

1. Slide pulse wheel assembly until the alignment surface of the unit is even with recess in face of enclosure. See Figure 2-3 for a detailed drawing of the pulse wheel assembly.
2. Use a straight edge to check it.
3. Loosen two set screws and slide pulse wheel along the shaft until the recess and wheel surfaces are aligned to within ± 0.010 inch.
4. Tighten two set screws to a nominal 15 inch-pounds.

If the pulse wheel is not lined up and pre-drilled holes are desired, use the following optional procedure to locate (or relocate) set screw holes in the shaft.



If pre-drilled screw holes turn out to be incorrectly placed, new screw holes must be drilled. New holes may be drilled plus or minus the error distance from the old holes.

1. Leaving one of set screws tightened, remove other set screw and use a punch to mark position of set screw hole on shaft.
2. Replace and tighten set screw. Remove other set screw and use a punch to mark position of that set screw hole on shaft.
3. Remove enclosure and pulse wheel.
4. Use standard 1/4" drill to drill a hole that is approximately 0.1" deep from tangent point of shaft (point of first contact of drill to shaft) to bottom of hole. Do this for both holes.
5. Reassemble pulse wheel and tighten set screws to a nominal 15 inch-pounds.
6. Reassemble enclosure onto motor facing.

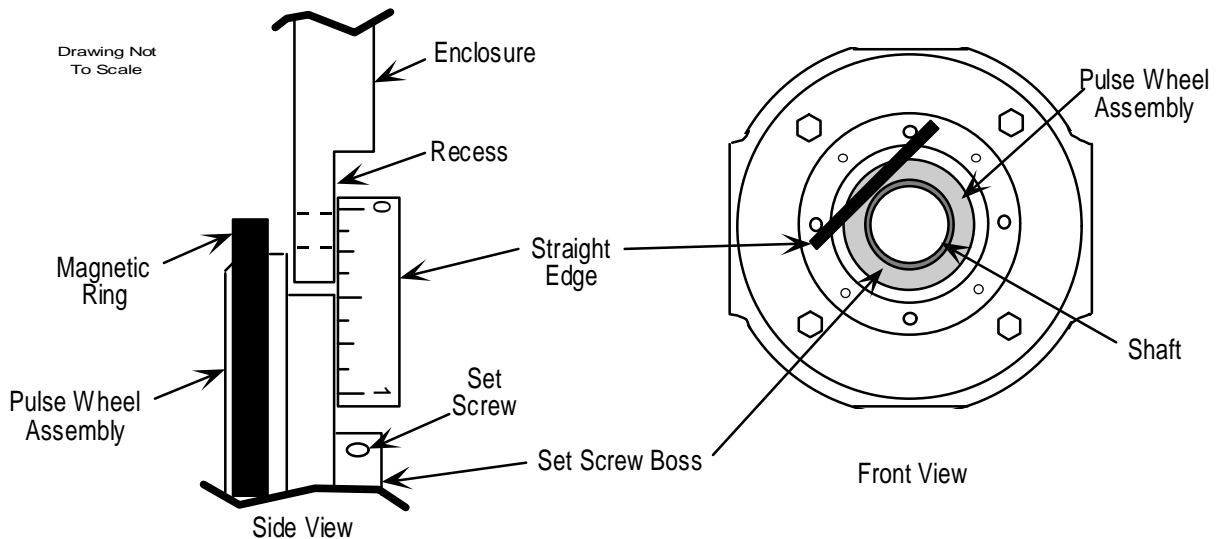

Figure 7: Pulse Wheel Alignment Check Using Straight Edge

2.2.5 Enclosure Installation

To prepare the enclosure for installation, perform the following steps (see Figure 6).



Do not attempt to mount or dismount the enclosure with sensor probe module(s) installed. Remove all sensor modules until enclosure mounting is complete.

1. Insert four 1/2"-13 mounting studs so the inside threaded portion is completely absorbed by the motor frame. This will set the mounting stud to the correct length. Torque the mounting studs to a nominal 40 foot-pounds. The mounting studs support the weight of the enclosure during installation permit better alignment to the motor, and prevent the Pulse Wheel from being damaged.
2. Remove red rubber band from pulse wheel. If test fitting the enclosure, leave rubber band in place until final enclosure mounting.
3. Remove enclosure from packaging.
4. Determine which of two orientations of enclosure is best for this application (Sensor Modules horizontal or vertical).



If mounted horizontally, ensure that the drain hole is at bottom of enclosure. If not, rotate the unit 180°.

5. Place enclosure on rods and slide on to motor facing.



Do not damage the pulse wheel when mounting the enclosure. If the pulse wheel assembly is not far enough down the shaft, continue pushing it on with the enclosure until the enclosure seats.

6. Tap lightly with hand or hammer if needed to make the enclosure slide over motor facing. Make sure clearance holes remain aligned.
7. Insert four 1/2"-13 cap nuts onto the remaining exposed mounting studs. If the enclosure has not already seated against the motor facing, do so by tightening the first bolt and then the bolt on the opposite side. Continue alternating and tightening until enclosure is seated. Torque all cap nuts to a nominal 40 foot-pounds.

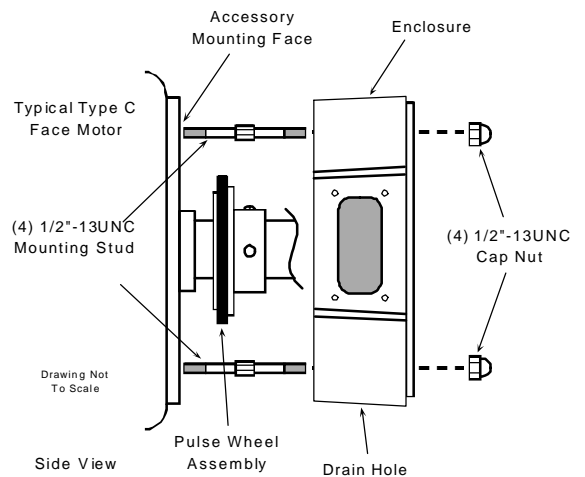

Figure 8: Enclosure Installation

2.2.6 Pulse Wheel Alignment Check

An optional and more accurate pulse wheel alignment check procedure is provided as follows (*see Figure 7*).

1. Locate four 5/16-inch diameter access holes on recessed area in the face of the enclosure. Access holes are located on a 4.63 diameter Bolt Center (BC).
2. Using a calibrated depth measuring tool (depth gauge, vernier caliper, etc.), measure through access hole to obtain distance between recessed surface on enclosure and aluminum magnetic ring underneath.



Ensure the gage is measuring the distance to the flat surface of the aluminum magnetic ring and has not engaged the edge of the steel hub or slipped past the edge of the pulse wheel.

3. Repeat for all four access holes. Take an average of all four readings.



The range (difference between high and low measurements) of readings should be less than 0.005 inch. If the range of the readings is greater, than this, the pulse wheel is not perpendicular to the shaft and will appear to wobble during shaft rotation. Tap the edge of the pulse wheel to bring it back in line.

4. The distance between surface of the recess in the face of the enclosure and silver aluminum magnetic ring should be 0.792 ± 0.010 inch. If the measurement does not correspond this depth, the position of the pulse wheel assembly should be adjusted. Refer to Section 2.6 for information on adjusting axial position of pulse wheel assembly.

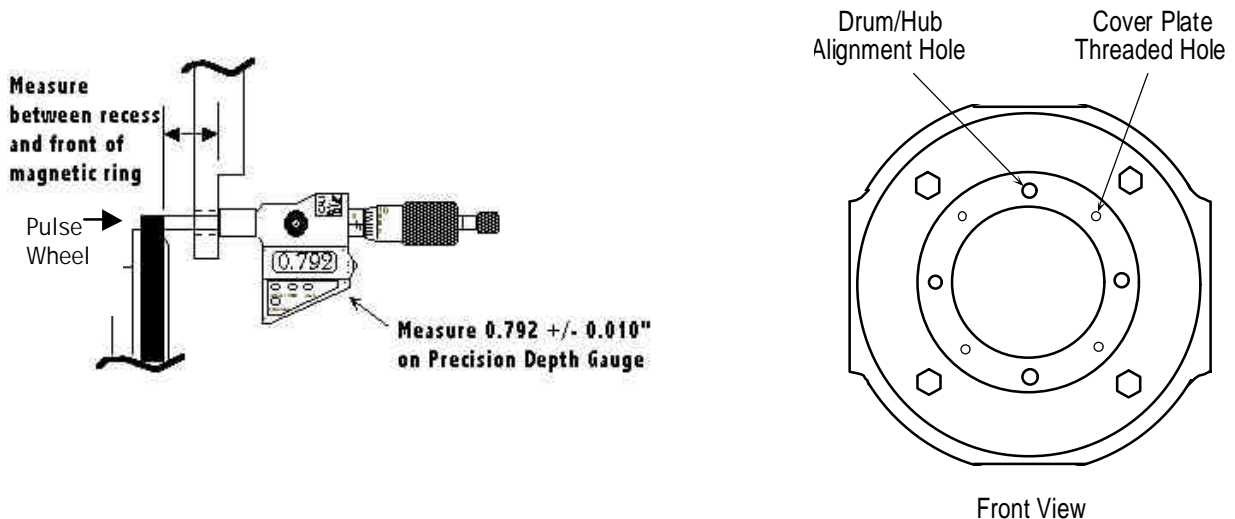

Figure 9: Optional Pulse Wheel Alignment Check With Depth Gauge

2.2.7 Sensor Module(s) Installation

To install a Sensor Module, perform the following steps (*see Figure 8*).

1. Remove sensor module and mating connector from packaging.



Although the device is protected from Electrostatic Discharges up to 2000 Volts, standard ESD precautions should be followed.

2. Separate mating connector from sensor module by releasing the two latches.



Use caution when handling the sensor module. The sensor at the end of the module can be easily damaged by sharp objects. The sensor module can be damaged by sudden shocks (dropping, hammer blows, etc.)

3. Insert sensor module into opening in enclosure. The sensor assembly is keyed to ensure proper orientation (blue side goes toward motor facing).
4. Locate four shoulder screws. Insert shoulder screws through clearance holes in sensor module and into tapped holes in enclosure. Tighten to a nominal 5 inch-pounds.



There should not be a gap between the lip on the housing and the enclosure. The stainless steel sensor module is designed to seat in metal-to-metal contact with the enclosure. Ensure that no gaskets, paint, dirt, etc., interfere with the complete seating of the module in the enclosure.

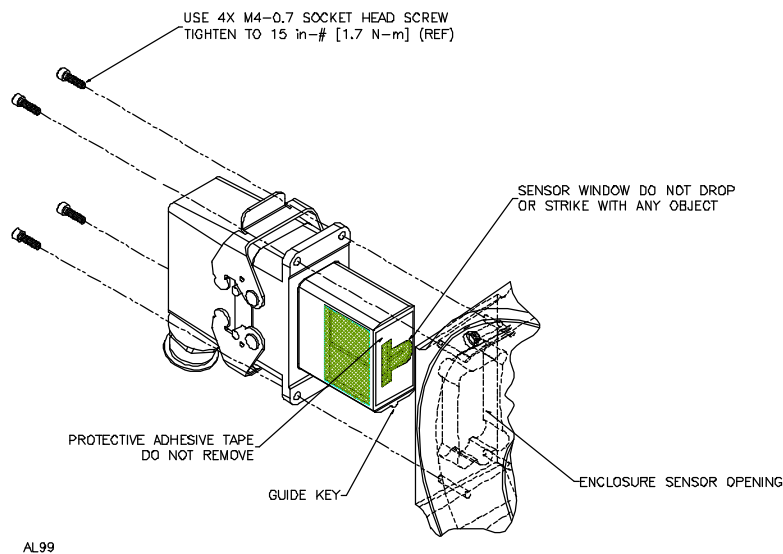

Figure 10: Sensor Module(s) Installation

2.3 Electrical Installation

Electrical connections are made to the sensor module through a standard 1/2 inch NPT liquid tight flexible conduit. The nipple length may be changed to extend the outlet box if desired. Interconnection cable recommendations are as follows: stranded copper, 22 through 16 gage, braided or foil with drain wire shielding 0.05 μ F maximum total mutual or direct capacitance, outer sheath insulated. Shrink tubing may be placed over any wires without insulation. For lengths over 100 feet, use 18 gage or larger, to a maximum of 1000 feet. If shielded twisted pair wire is used, do not cross channels. Keep each pair of complementary channel outputs together in a single twisted pair (e.g., A and A). NorthStar offers a general purpose Encoder Connection Cable (Part # RIM Cable DB1)



Reversing power and common will not damage the unit. However, applying power to any of the sensor outputs may cause damage.

Table 1. Signal Coding Table

Signal	Connector Pin	Pigtail Cable	MS 3102E18-IT#
Common	1	Black	A
B	2	Green	E
A	3	Blue	D
Z *	4	Violet	C
No Connection	5	-----	-----
Vcc (5-15 VDC)	6	Red	B
B	7	Yellow	H
A	8	Gray	G
Z *	9	Orange	I
Shield	10	Braid	J

* Applies only to units with index pulse capability.

Pinouts are for the sensors with the MS 3102E18-IT connector



The shield in the sensor module is isolated from the frame of the encoder. For maximum noise immunity, the shield wire or pin should be connected to the shield of the cable and that of the drive or other receiving device.

2.3.1 Quick Release Connector Hood Wiring

To install the Quick Release Connector, perform the following steps.

1. Remove the four screws from the mating connector housing that hold the terminal block in place. Remove terminal block from housing.
2. Insert wiring through liquid tight flexible seal and mating connector housing. Leave enough wire exposed to comfortably reach the terminal block. Wire to terminal block according to wire code in Table 1. A similar wiring list is attached to enclosure.



There are two orientations of the connector hood. The terminal block can be inserted either way so the connector hood points up or down. Choose the direction best for your application.

4. Tighten Liquid Tight fitting on housing. **OPTIONAL:** In some hostile environments, seal between connector body and Sensor Module can be improved by smearing a sealant (silicone grease, etc.) on the neoprene seal of the connector.
5. Mate connector into place on sensor mount and snap the two latches into place. If only one sensor is being installed, ensure cover plate is installed over other sensor hole.

2.4 Returning Equipment to Danaher Controls

If it is necessary to return the unit for repair or replacement, a **Return Goods Authorization (RGA)** number must be obtained from a factory representative before returning the equipment to our service department. When returning an instrument for service, the following information must be provided before we can attempt any repair.

1. Instrument model and serial number
2. User's name, company, address, and phone number
3. Malfunction symptoms
4. Description of system
5. Returned Goods Authorization number

Consult the factory for shipping instructions.