

NorthStar brand

Instruction Manual

Rim Tach \odot 6200 Digital Tachometer

Designed for use in
**4.5" 56C-Face, Coupled, Foot Mounted,
or Pulley Driven Applications**



Danaher Controls

1675 Delany Road

Gurnee, IL 60031

Ph: 847-662-2666

Fax: 847-662-6633

www.NorthStarEncoders.com

791-1003-00

Table of Contents

| Chapter/Paragraph/Illustration | Page |
|---|------|
| 1 Introduction | 4 |
| 1.0 Safety Summary | 4 |
| 1.1 General | 5 |
| 1.2 Description | 5 |
| <i>Figure 1: 6200 Dimensional Drawing</i> | 5 |
| 1.3 Safety Summary | 6 |
| 2 Installation | 7 |
| 2.0 Inspection and Unpacking | 7 |
| <i>Figure 2: 6200 Spare Parts</i> | 7 |
| 2.1 Painting Considerations | 8 |
| 2.2 56 C-Face Bracket Mounting | 8 |
| <i>Figure 3: Model 6200 56 C Bracket Mounting</i> | 8 |
| 2.3 Foot Mounting | 9 |
| <i>Figure 4: Model 6200 Foot Mounting</i> | 9 |
| 2.4 Pulley Mounting | 10 |
| <i>Figure 5: Model 5200 Pulley Mounting</i> | 10 |
| 2.5 Sensor Module Installation | 11 |
| <i>Figure 6: Sensor Module Installation</i> | 11 |
| <i>Figure 7: Sensor Module Installation (Continued)</i> | 12 |
| 2.6 Electrical Installation | 13 |
| 2.6.1 Quick Release Connector Hood Wiring | 13 |
| <i>Figure 8: Quick Release Connector Installation</i> | 14 |

Methods and apparatus disclosed and described herein have been developed solely on company funds of Danaher Controls No government or other contractual support or relationship whatsoever has existed which in any way affects or mitigates proprietary rights of Danaher Controls in these developments. Methods and apparatus disclosed herein may be subject to U.S. Patents existing or applied for. Danaher Controls reserves the right to add, improve, modify, or withdraw functions, design modifications, or products at any time without notice. NorthStar shall not be liable for errors contained herein or for incidental or consequential damages in connection with furnishing, performance, or use of this material.

CHAPTER 1

INTRODUCTION

1.0 Safety Summary

High current, voltage, and rotating parts can cause serious or fatal injury. The use of electric machinery, like all other uses of concentrated power and rotating equipment, may be hazardous. Only qualified personnel should install, operate, and maintain electric machinery in accordance with applicable provisions of the National Electrical Code and sound local practices. Failure to comply with these precautions or with specific warnings elsewhere in this manual violates safety standards of design, manufacture, and intended use of the instrument. Danaher Controls assumes no liability for the customer's failure to comply with these requirements.

Rotating Machinery

Avoid contact with rotating parts. Avoid by-passing or rendering inoperative any safety guards or protection devices. Avoid extended exposure in close proximity to machinery with high noise levels. Use proper care and procedures in handling, lifting, installing, operating and maintaining the equipment.

Before Installation

Safe maintenance practice with qualified personnel is imperative. Before starting maintenance procedures, be positive that, (1) equipment connected to the shaft will not cause mechanical rotation, (2) main machine windings have been disconnected and secured from all electrical power sources, and (3) all accessory devices associates with the work area have been de-energized. If high potential insulation test is required, follow procedures and precautions outlined in NEMA standards MG-1.

Grounding

Improperly grounding the frame of the machine can cause serious or fatal injury to personnel. Grounding of the machine frame and structure should comply with the National Electrical Code and with sound local practices. Check wiring diagram before connecting power.

Do Not Operate In An Explosive Atmosphere

Do not operate the instrument in the presence of flammable gases or fumes. Operating any electrical instrument in such an environment constitutes a definite safety hazard.

Keep Away From Live Circuits

Operating personnel must not remove instrument covers. Qualified maintenance personnel must make component replacement and internal adjustments. Do not replace components with power cable connected. To avoid injuries, always disconnect power and discharge circuits before touching them.

Do Not Substitute Parts Or Modify Instrument

Do not install substitute parts or perform any unauthorized modification to the instrument. Introducing additional hazards is dangerous. Return the instrument to an authorized Danaher Controls representative for service and repair to ensure that safety features are maintained.

Dangerous Procedure Cautions

A CAUTION heading precedes potentially dangerous procedures throughout this manual. Instructions in the warnings *must* be followed.

1.1 General

These instructions do not claim to cover all details of variation in equipment or to provide for every possible contingency or hazard met in connection with installation, operation, and service. If further information is desired or should particular problems arise which are not covered sufficiently for the purchaser's purposes, please contact Danaher Controls, or one of its designated representatives.

1.2 Description

The RIM Tach[®] 6200 is a high performance and reliable Digital Tachometer, designed to provide position and velocity feedback from both AC and DC electric motors with pulse counts ranging from 60 through 2048 pulses per revolution. The RIM Tach 6200 utilizes rugged ductile iron casting construction and provides interchangeable sensor modules and a magneto-resistive technology capable of withstanding the harshest industrial environments. This ensures precise and consistent digital motor speed feedback.

The NorthStar RIM Tach[®] 6200 is mounted in a variety of ways and utilizes a patented, heavy-duty, one piece, magneto-resistance sensor module with encapsulated surface mount electronics. The encapsulation provides resistance to water, oil mist, dirt, high temperatures, and other harsh environments. The sensor module includes a 10-pin quick connector requiring only a screwdriver for final electrical installation. The non-contact magneto-resistive sensor and rugged magnetized pulse wheel are designed and machined to function properly without any adjustments. The RIM Tach 6200 provides precise, reliable speed signals for many monitoring and control applications, and is a standard feedback device for AC and DC variable speed drives. The unit is bi-directional providing square wave outputs.

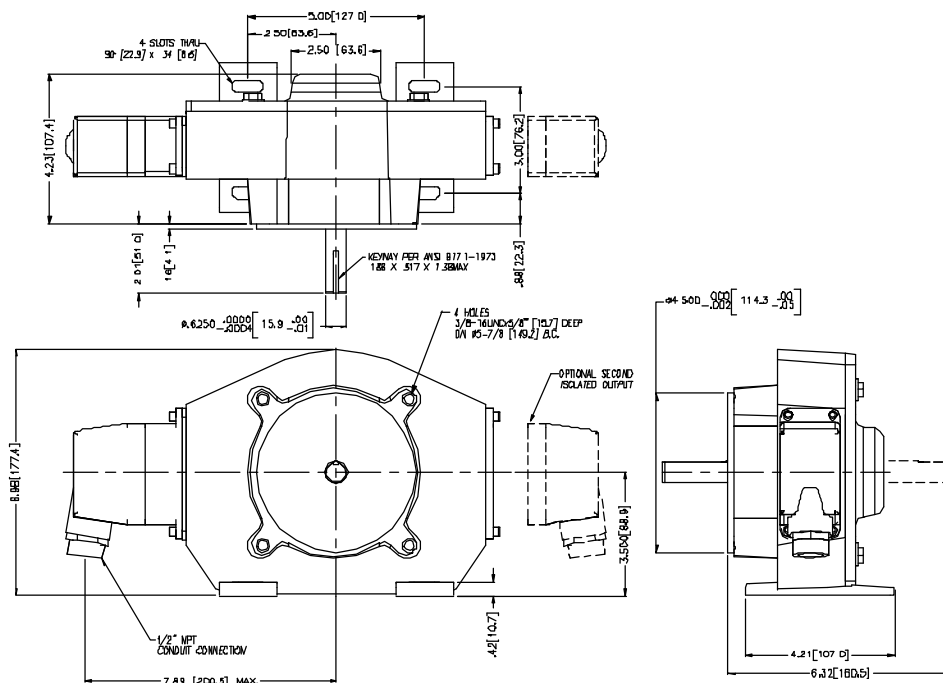

Figure 1: 6200 Dimensional Drawing

1.3 Specifications

| Electrical Specifications | |
|-------------------------------------|--|
| Frequency Response | 0 - 120 kHz |
| Pulse Code | A, B, Z (Index), and complements (A, B, Z) |
| Output Phases | A phase, B phase @ quadrature 90°, Z phase: Once per rev. (gated) |
| Pulse Duty Cycle | 50 ± 15% (within defined mechanical specifications) |
| Quadrature Accuracy | 90 ± 22° (within defined mechanical specifications) |
| Output Type | High speed, differential line driver |
| Rise and Fall Time | Less than 1µs @ 10,000 pf typical load |
| Current Consumption | 45 mA typical plus line driver load |
| Output Current | 150 mA maximum continuous |
| ESD Protection | 2kV |
| Mechanical Specifications | |
| Enclosure Configurations | 4.5-inch diameter, 56 C motor face or accessory flange to meet NEMA MG1-4 standards; foot mount with 4 slotted bolt holes |
| Material | Ductile iron cast enclosure, stainless steel probe module |
| Shaft Interfacing | 0.625 inch diameter x 1.87 inch long, 3/16" square-parallel key, optional double ended shaft, optional 14 mm shaft with metric key |
| Maximum Operational Speed | 7,000 RPM (120khz) |
| Axial, Radial Load | 15 lbf axial, 50 lbf radial |
| Slew Rate | 3600 RPM/second |
| Approximate Box Weight | 28lbs. |
| Box Dimensions | 21" x 10" x 10" |
| Environmental Specifications | |
| Operational Temperature | -40° to +80° C |
| Operational Humidity Range | Maximum of 90% |
| Chemical Resistance | Salt spray, most solvents, mild acids and bases |
| Vibration | Minimum 18 g's RMS, 5-2000 Hz shock spectrum |
| Shock (Sensor Module) | 1 meter drop tested, min. 30g's |
| Interface Specifications | |
| Power | +5.0 to +15.0 VDC |
| Output | Differential output swinging between Vcc - 0.6V and ground |
| Connector | 10 pin industrial latching connector with ½ inch NPT fitting, IP-65 NEMA 4, 12 rated |
| Suggested Cable | 22 - 16 AWG, 10 conductor, shielded, twisted pair |

Specifications subject to change without notice.

CHAPTER 2

INSTALLATION

2.0 Inspection and Unpacking

Inspect shipping container for external damage. All claims for damage (apparent or concealed) or partial loss of shipment must be made in writing to NorthStar within (5) days from receipt of goods. If damage or loss is apparent, please notify the shipping agent immediately.

Open shipping container and locate the packing list. The packing list is included to verify that all components, accessories, and manual were received. Please use the packing list to check off each item as the unit is unpacked. Inspect for damage. We recommend that the shipping container be retained for future shipping, storage, or return to factory purposes.

If any equipment was damaged in transit, be sure to file proper claims promptly with the carrier and insurance company. Please advise us of such filing. In case of part shortages, advise us immediately. Danaher Controls cannot be responsible for any missing parts unless notified within 60 days of shipment.

The RIM Tach[®] 6200 utilizes a modular construction that permits the user to configure the unit as a one or two signal output tachometer. Sensor modules are universal and interchangeable. If one output requires replacement, simply remove four screws, and replace with a new sensor module. No electrical adjustment or alignment is required. After unpacking the unit and verifying receipt of the items listed in the packing list, you may proceed with mechanical installation.

The Model 6200 has no user maintainable components. The bearings are permanently lubricated and sealed for the operational life of the unit. The Pulse Wheel also needs no service. Disassembly of the unit will void the Warranty. The magnetoresistive sensor end electronics modules need no adjustment, but can be replaced by the user in case of failure.

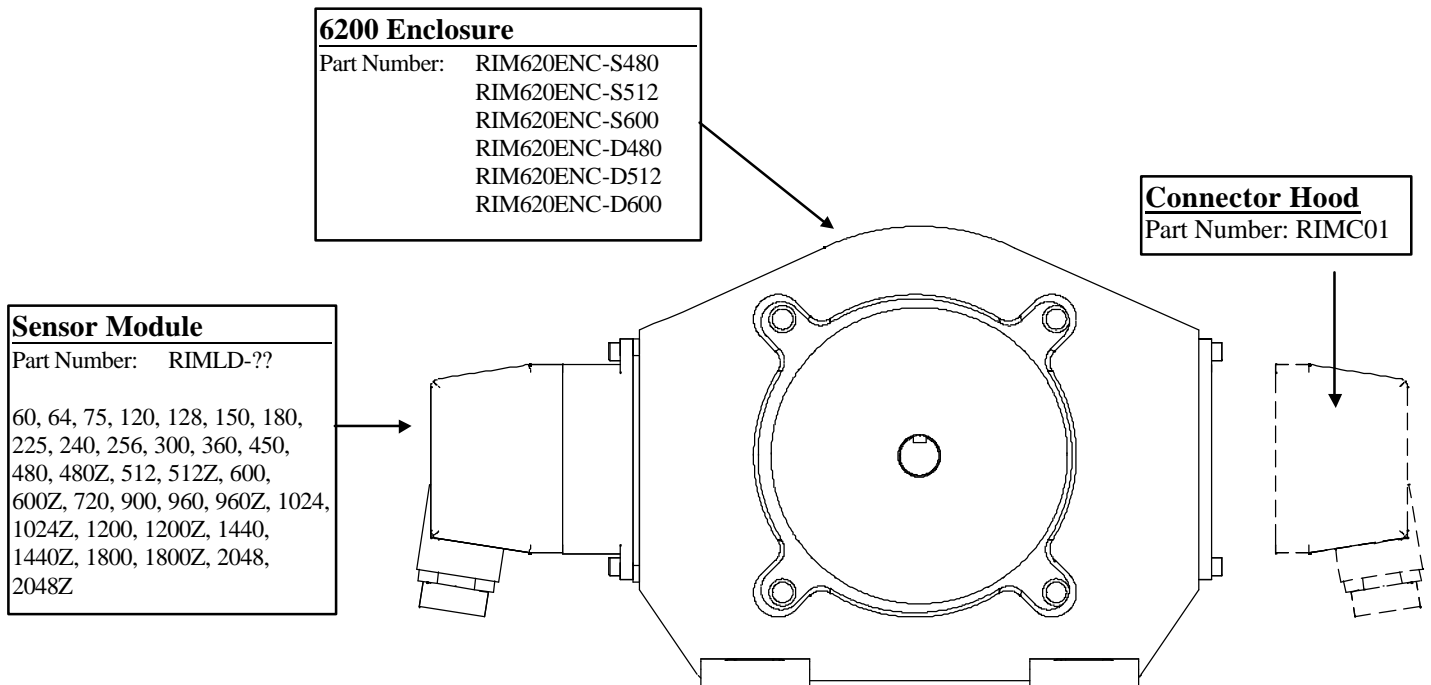

Figure 2: 6200 Spare Parts

2.1 Painting Considerations

The enclosure may be painted. Please pay attention to the following considerations.

NOTE

Corrosion preventative coating has been applied to the enclosure. Standard degreasing practices must be followed before applying paint.

- Do not hinder the latches on the connector if the connector is painted.
- If the enclosure is painted before the sensor module(s) is added, be sure to mask off the area where the sensor module(s) will be placed. The module must mate directly to the enclosure with nothing between. Failure to do this will degrade the alignment of the system and may cause it to fail.
- Ensure excess paint runoff does not clog enclosure drain holes.

2.2 56 C-Face / Bracket Mounting

Flexible couplings are generally used to couple the Model 6200 to its driver (NorthStar part number RIMFLEX-5858). There are a wide variety of speeds, loads, environment, and alignment conditions found in various applications. If there is doubt to suitability, we recommend you consult the flexible coupling manufacturer on your particular application requirement. One simple design of coupling can not fulfill all potential applications or conditions.

1. Mount the C-Face adapter bracket (not supplied) onto the motor per manufacture's instructions. See Figure 3. Be sure the 4.5 inch C-Face is concentric to the motor shaft.
2. Insert flexible coupling onto the motor shaft. Do not tighten at this time.
3. Place the Model 6200 onto the 4.5 inch C-Face. Insert and tighten four 3/8-16 UNC bolts. Be sure it is seated flat against the mounting bracket.
4. Connect flexible coupling onto the Model 6200 shaft and tighten per manufacturer's specifications.
5. Rotate the shaft by hand to ensure free rotation.
6. Place or replace appropriate safety shields.

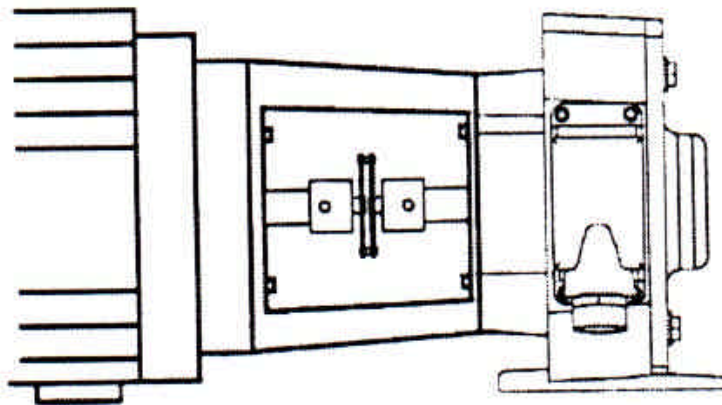

Figure 3: Model 6200 56 C Face/ Bracket Mounting

2.3 Foot Mounting

Foot mounting brackets are included on the bottom of the Model 6200. The bolt hole pattern is slotted to permit a measure of adjustment. Flexible couplings are generally used to couple the Model 6200 to its driver (NorthStar part number RIMFLEX-5858). There are a wide variety of speeds, loads, environment, and alignment conditions found in various applications. If there is doubt to suitability, we recommend you consult the flexible coupling manufacturer on your particular application requirement. A simple coupling design can not fulfill all potential applications or conditions.

1. Place the Model 6200 mounting bracket in the approximate final position.

NOTE

The mounting should be strong enough to sufficiently support the weight of the Model 6200 (approximately 25 pounds) without excessive deflection due to load or vibration. Deflection can cause erroneous outputs and shorten the operational life of the unit.

2. Insert, but do not tighten, four 3/8-16 UNC bolts into the mounting bracket holes.
3. Insert and connect flexible coupling onto the motor and Model 6200 shaft per manufacture's specifications.

NOTE

The life expectancy of the flexible coupling and Model 6200 are influenced by the accuracy to which the shafts are aligned in this step.

4. Tighten mounting bolts to nominal 30 foot-pounds.
5. Rotate shaft by hand to ensure free rotation.
6. Place or replace appropriate shields.

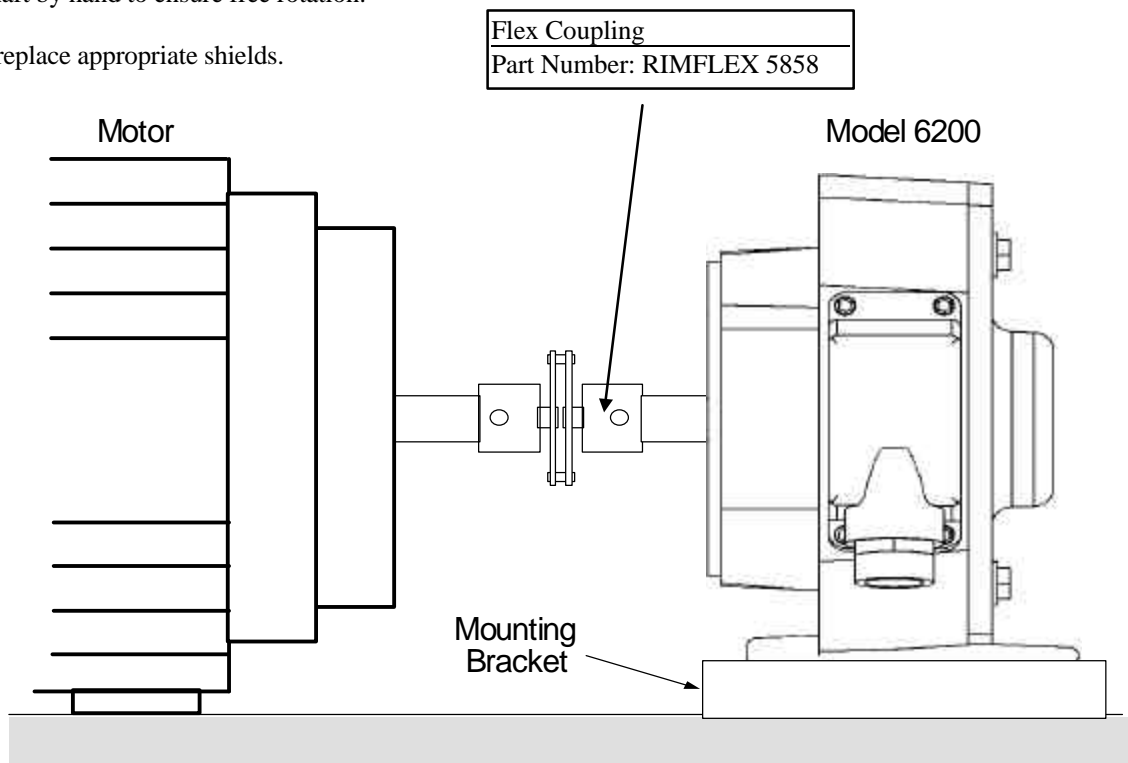

Figure 4: Model 6200 Foot Mounting

2.4 Pulley Mounting

1. Mounting the Model 6200 onto mounting bracket with four 3/8-16 UNC bolts through foot mounting bracket holes.

NOTE

The mounting bracket should be strong enough to sufficiently support the weight of the Model 6200 (approximately 25 pounds) without excessive deflection of play due to load or excessive vibration. Deflection can cause erroneous outputs and shorten operational life of the unit.

2. Mount and connect 5/8 inch I.D. pulley on to the Model 6200 input shaft.
3. Install a tension belt according to the manufacturer's specifications. If the belt tension is too light it can cause pulley slippage or backlash, thereby creating an erroneous signal output. However, for maximum operational life of the Model 6200, a belt tension loading of less than 40 pounds should be used.

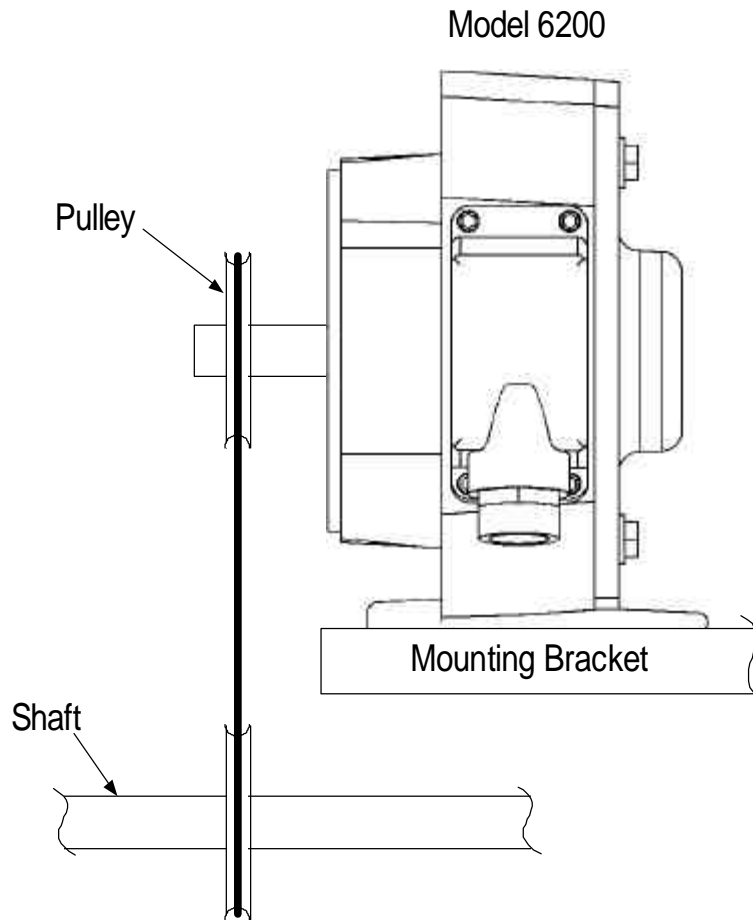

Figure 5: Model 6200 Pulley Mounting

2.5 Sensor Module Installation

To install the sensor Module, perform the following steps. See Figure 6.

1. Remove sensor module and mating connector from packaging.

CAUTION!

Although the device is protected from Electrostatic Discharges up to 2000 Volts, standard ESD precautions should be followed.

2. Separate mating connector from sensor module by releasing the two latches.

CAUTION!

Use caution when handling the sensor module. The sensor at the end of the module can be easily damaged by sharp objects. The sensor module can be damaged by sudden shocks (dropping, hammer blows, etc.).

3. Insert sensor module into opening in enclosure. The sensor assembly is keyed to ensure proper.
4. Locate four shoulder screws. Insert shoulder screws through clearance holes in sensor module and into tapped holes in enclosure. Tighten to a nominal 5 inch-pounds.

CAUTION!

There should not be a gap between the lip on the housing and the enclosure. The stainless steel sensor module is designed to seat in metal to metal contact with the enclosure. Ensure that no gaskets, paint, dirt, etc., interferes with the complete seating of the module in the enclosure.

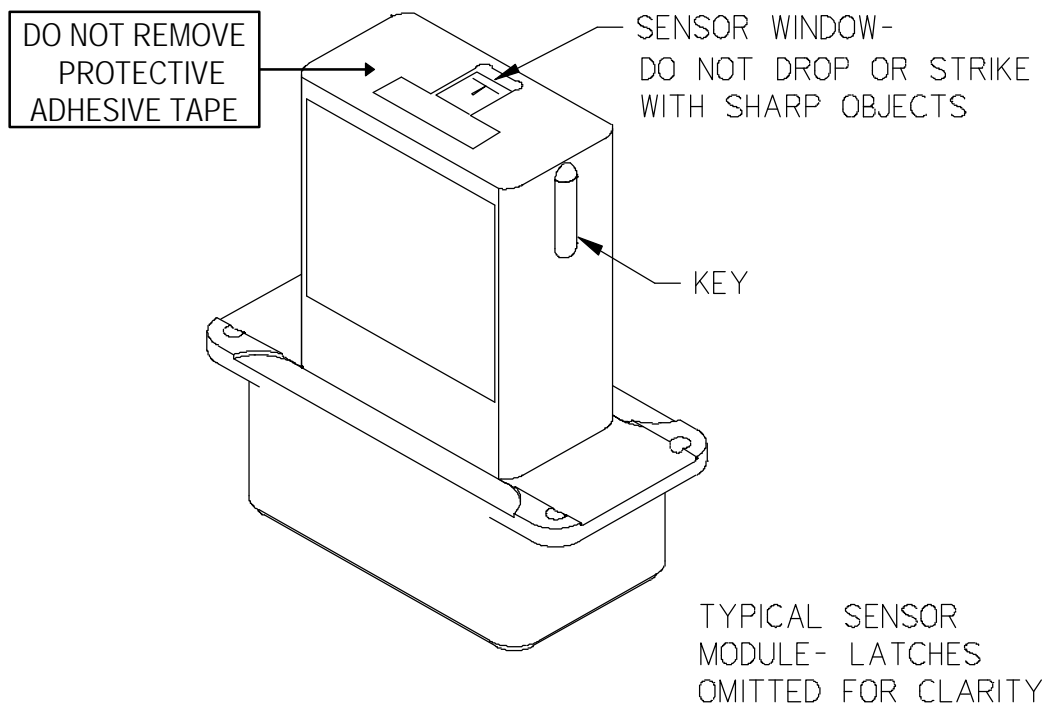

Figure 6: Sensor

Module Installation

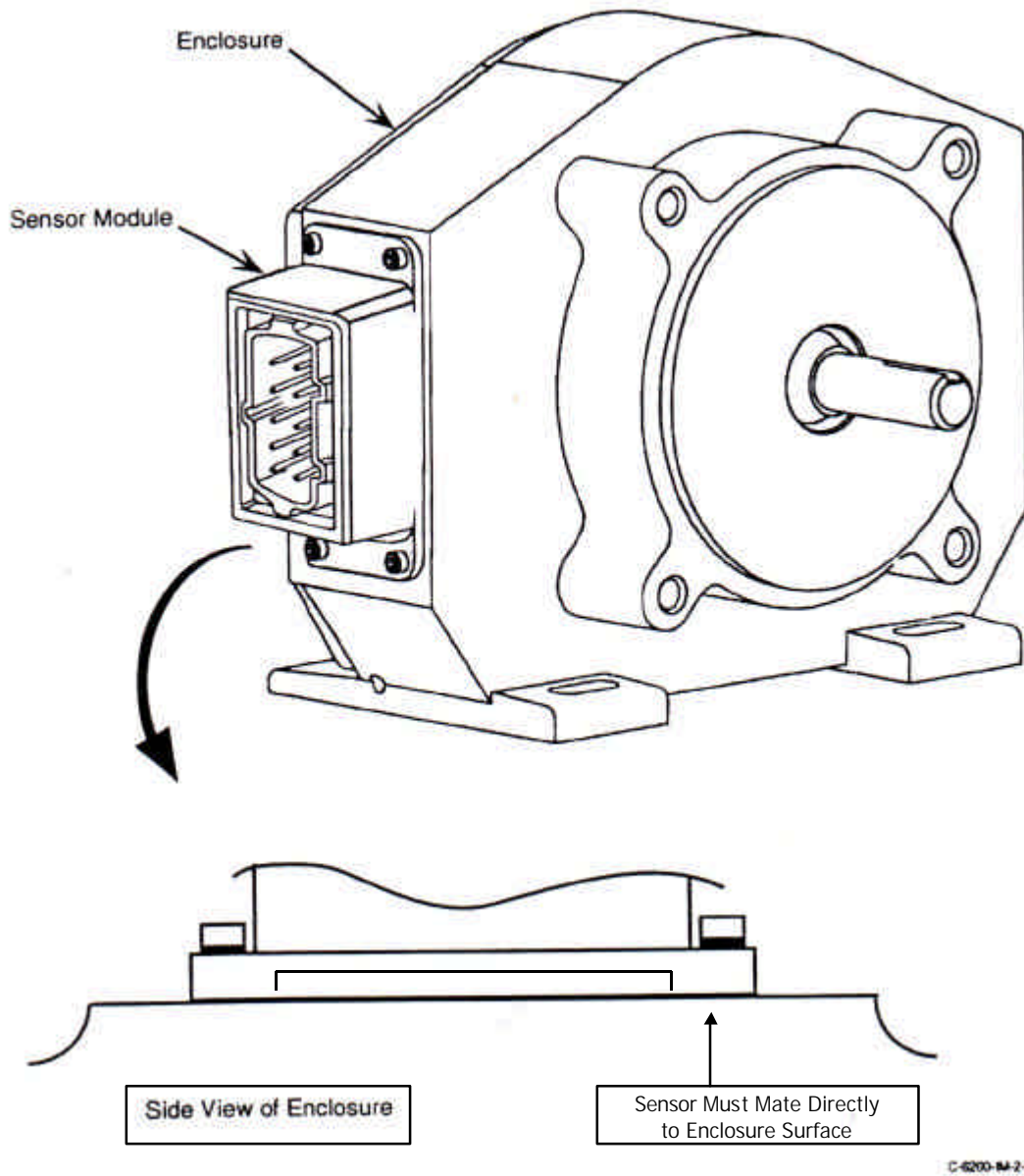

Figure 7: Sensor Module Installation (Continued)

2.6 Electrical Installation

Electrical connections are made to the sensor module through a standard 1/2 inch NPT liquid tight flexible conduit. The nipple length may be changed to extend the outlet box if desired. Interconnection cable recommendations are as follows: stranded copper, 22 through 16 gage, braided or foil with drain wire shielding 0.05 µF maximum total mutual or direct capacitance, outer sheath insulated. Shrink tubing may be placed over any wires without insulation. For lengths over 100 feet, use 18 gage or larger, to a maximum of 1000 feet. If shielded twisted pair wire is used, do not cross channels. Keep each pair of complementary channel outputs together in a single twisted pair (e.g., A and A complement).

CAUTION!

Reversing power and common will not damage the unit. However, applying power to any of the sensor outputs may cause damage.

Table 1. Signal Coding Table

| Signal | Connector Pin | Pigtail Cable | MS 3102E18-IT# |
|----------------|---------------|---------------|----------------|
| Common | 1 | Black | A |
| B | 2 | Green | E |
| A | 3 | Blue | D |
| Z * | 4 | Violet | C |
| No Connection | 5 | ----- | ----- |
| Vcc (5-15 VDC) | 6 | Red | B |
| /B | 7 | Yellow | H |
| /A | 8 | Gray | G |
| /Z * | 9 | Orange | I |
| Shield | 10 | Braid | J |

* Applies only to units with index pulse capability.

Pinouts are for the sensors with the MS 3102E18IT connector

NOTE

The shield in the sensor module is isolated from the frame of the encoder for maximum noise immunity. The shield wire or pin should be connected to the shield of the cable and that of the drive or other receiving device.

2.7 Quick Release Connector Hood Wiring

To install the Quick Release Connector, perform the following steps.

1. Remove the four screws from the mating connector housing that hold the terminal block in place. Remove terminal block from housing.
2. Insert wiring through liquid tight flexible seal and mating connector housing. Leave enough wire exposed to comfortably reach the terminal block. Wire to terminal block according to wire code in Table 1. A similar wiring list is attached to enclosure.

NOTE

There are two orientations of the connector hood. The terminal block can be inserted either way so the connector hood points up or down. Choose the direction best for your application.

4. Tighten Liquid Tight fitting on housing. **OPTIONAL:** In some hostile environments, seal between connector body and Sensor Module can be improved by smearing a sealant (silicone grease, etc.) on the neoprene seal of the connector.
5. Mate connector into place on sensor mount and snap the two latches into place. If only one sensor is being installed, ensure cover plate is installed over other sensor hole.

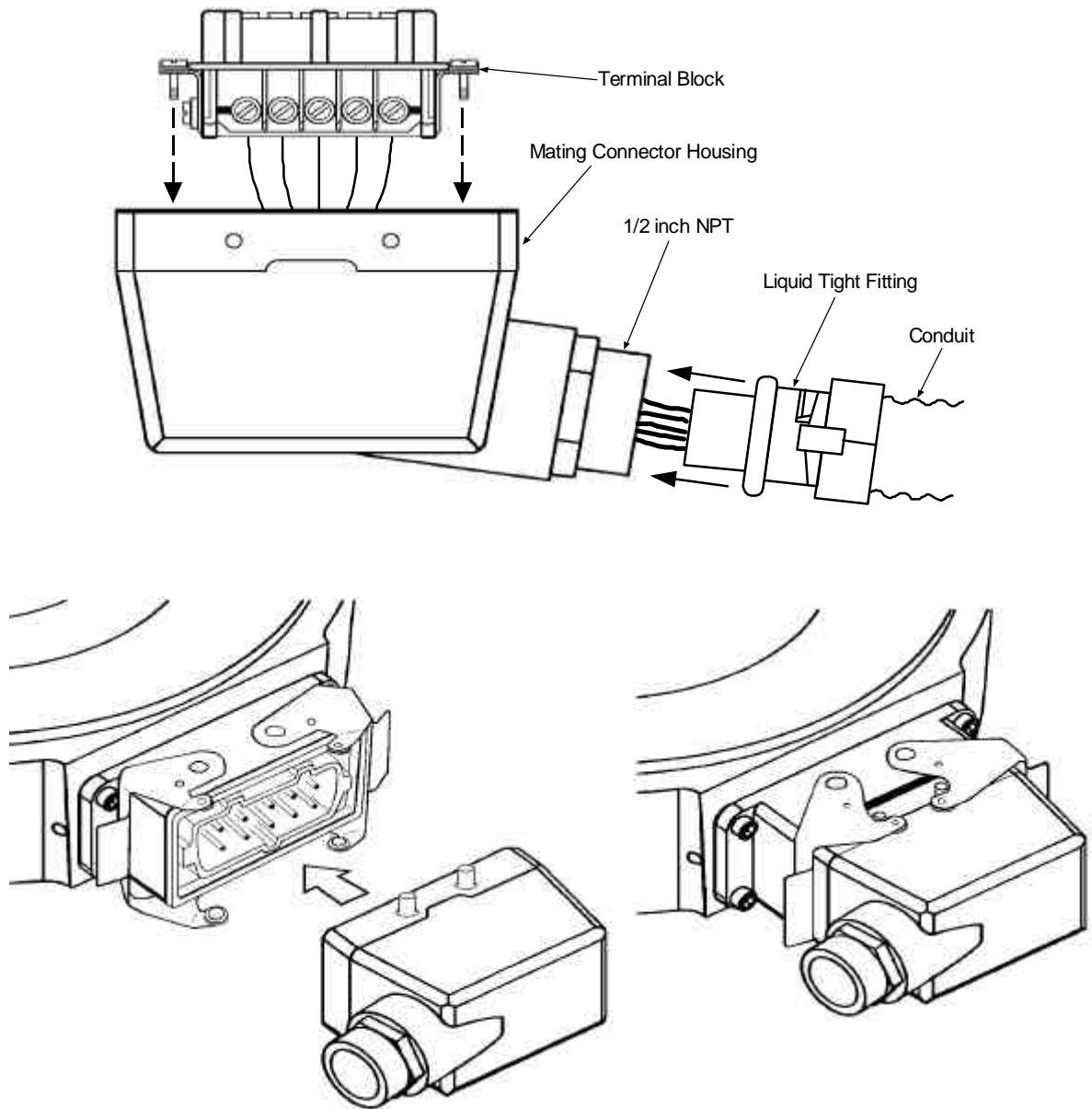

Figure 8: Quick Release Connector Installation



1675 Delany Road
Gurnee, IL 60031
Ph: 847-662-2666
Fax: 847-662-6633
www.NorthStarEncoders.com