

Basics of Incremental Encoders

Outputs - Alarm

OUTPUT CIRCUIT

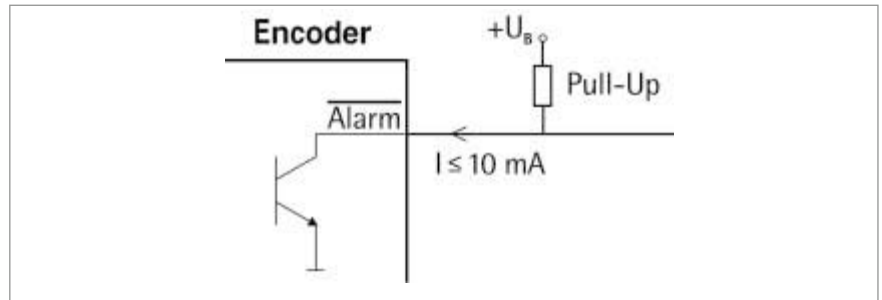

TECHNICAL DATA

Output	NPN - Open collector
Output load max.	5 mA / 24 V at $U_B = DC 5 V$ 5mA / 32 V at $U_B = DC 10- 30 V$
Output level	Output active (failure condition): $L \leq DC 0,7 V$ Output inactive: high impedance (if necessary: get H-level by an external pull-up resistor)
Malfunction indication time	$\geq 20 ms$

FUNCTION

The rotary encoders are equipped with an electronic monitoring system that reports potential malfunctions via a separate alarm output.

The alarm output can be used for selecting an optical display (LED; for circuit, see above) or the control system (SPC or similar).

Moreover, the alarm outputs of several encoders can be interconnected to a common "systems alarm" by means of a parallel connection. The following errors are indicated:

Category I	Category II	Category III
- damaged disks	- overtemperature	- voltage range $1 VDC < U < 4 VDC$
- defective LED	- overload (e. g. due to short circuit)	- voltage drop on the supply lines
- contamination		

Category I malfunctions cannot be corrected; the encoder must be replaced.

Category II malfunctions are detected by means of a thermal monitoring unit in the electronic system. The alarm message is cleared after the cause of temperature increase has been removed.

Category III malfunctions indicate insufficient supply voltage. Also included in this category are transients in the supply voltage, e.g. due to electrostatic discharge, which may distort the output signals.

This is corrected by

- readjustment to the correct voltage
- eliminating the cause of disturbance, i.e. by careful arrangement of the cables.