

With Motor encoders Series M – Optimal control of motor feedback –

Hengstler supplies the new high-performance motor encoder series M for use with brushless servo motors and stepper motors. These new encoders are a modern, cost-efficient alternative to resolvers and conventional self-bearing encoders. Users can select the encoder which matches exactly with their size of motor. Hengstler offers motor encoders in standard resolver dimensions of 1.5" (approx. 38 mm), type M15, and 2.1" = approx. 53 mm (type M21).

General description

The product concept is modular, i.e. the motor encoders M15 and M21 do not have a bearing of their own like conventional shaft or hollow-shaft encoders, but use the existing motor bearing. This concept offers interesting advantages such as:

- Virtually no rotational limitation
- Excellent dynamic behavior due to a low moment of inertia of the rotor which results in low retroactive impact on the motor
- No clutch as a transmission element, giving exceptional drive control factor
- Small dimensions (low mounting depth) and low weight

Function and features

The motor encoders M15 and M21 contain quadrature incremental tracks for the determination of the speed and position of the motor shaft. Additionally, they allow the rotor position to be determined by the commutation signals and control the commutation of brushless servomotors.

The new motor encoders offer outstanding performance and decisive competitive advantages in comparison to conventional modular encoders, e.g.:

- Increased temperature range, -40 to +120° C
- Incomparable shaft play tolerances (to 0.7 mm axial)
- Better frequency, 200 KHz
- Noise immunity/noise emission according to EN 50082-2 and EN 50081-2
- Higher number of pulses, up to 2,048 impulses
- Flexibility, since the user can integrate in all actual motor sizes
- Simple mounting and adjustment since encoders come aligned and gapped

A considerably improved positioning accuracy can be achieved by the Hengstler motor encoders in comparison to resolvers.

A further fact you will welcome is that the Hengstler motor encoders with all their features and advantages are available at an attractive price.



The new sine-wave flex-mount encoder S21 sets new standards.



This new sine-wave flex-mount encoder was developed especially to be used in brushless servo-motors in high-spec applications such as CNC or printing machines. These sort of applications set the highest demands on the drive characteristics.

The high sine-wave signal quality (harmonic distortion better than 1%) together with the interpolation of the 2,048 signal periods means that resolutions with more than 4,000,000 measurement steps can be achieved. The result of this, is for example, perfect surfaces with CNC machines. There is one sine/cosine signal period per revolution, for the electronic commutation of BLDC motors.

The heart of the sine-wave encoder is a new Hengstler sine-wave optoasic. This optoasic contains almost all the electronics and provides a high degree of safety against failure, through the reduction in the number of individual components. The encoder, containing its own bearings, has a conical shaft and a stator coupling. The resulting stable and concentric connection, together with the optimised stator coupling, means that the measurement system follows the highest motor angular accelerations with almost no delay. The tapered shaft is available in both hollow and solid shaft versions.

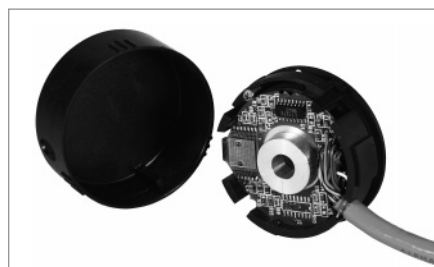
Motor Encoders



Type	M15	M21
Special features	<ul style="list-style-type: none"> ■ through hollow shaft, diameter 6 to 10 mm ■ output signals: A, B, N as incremental signals as well as 4, 6 or 8 pole commutation signals ■ external diameter only 40 mm (1.5") ■ mounting depth only 28 mm (1.1") ■ max. speed up to 12,000 RPM ■ operating temperature up to 120 °C ■ applications, e.g. as feedback for brushless DC (BLDC) servo motors, DC servomotors, step motors 	<ul style="list-style-type: none"> ■ through hollow shaft, diameter 6 to 12.7 mm ■ output signals: A, B, N as incremental signals as well as 4, 6, 8 or 12 pole commutation signals ■ external diameter only 53 mm (2.1") ■ mounting depth only 20 mm (0.8") ■ max. speed up to 12,000 RPM ■ operating temperature up to 120 °C ■ applications, e.g. as feedback for brushless DC (BLDC) servo motors, DC servomotors, step motors
Number of pulses	200 ... 1,024	500 ... 2,048
Technical Data – mechanical		
Flange or shaft fixation	clamping ring	clamping ring
Shaft diameter	hollow shaft 6 to 10 mm	hollow shaft 6 to 12 mm
Balance tolerances	misalignment axial +0.38 ... - 0.38 mm misalignment radial 0.05 mm (including angular misalignment)	misalignment axial +0.13 ... - 0.38 mm misalignment radial 0.05 mm (including angular misalignment)
Absolute max. speed	12,000 RPM	12,000 RPM
Protection class	IP 40	IP 40
General design		
Operating temperature	-40...+120 °C	-40...+120 °C
Connection	cable radial or PCB connector	cable radial or PCB connector
Size	Ø 40 mm	Ø 53 mm
Weight	approx. 23 g without cover, 28 g with cover	approx. 28 g without cover, 43 g with cover
Technical data – electrical		
Output	NPN-O.C./RS 422	NPN-O.C./RS 422
Supply voltage (SELV)	5 VDC/12 VDC ±10%	5 VDC/12 VDC ±10%
Max. intrinsic power consumption	incremental: max. 100 mA incremental + commutation: max. 120 mA	incremental: max. 100 mA commutation: max. 75 mA
Max. pulse frequency	200 kHz	200 kHz
Alarm output	NPN-O.C. 16 mA RS 422: ± 40 mA	NPN-O.C. 16 mA RS 422: ± 40 mA
Pulse shape		
Pulse duty factor	1 : 1	1 : 1
Pulse width tolerance	± max. 18° electrical	± max. 18° electrical
Page	192	197

Motor Encoders



Type	S21
Special features	<ul style="list-style-type: none"> ■ Operating temperature range of -15 up to +120 °C ■ 500 kHz limiting frequency with excellent signal quality ■ Excellent immunity to interference (EN 61000-4-4, Class 4) ■ Signal control and system monitoring ■ High signal quality through control and error compensation
Technical – data mechanical	
Shaft form	Conical 1/10
Shaft variations	Hollow and solid shaft
Shaft diameter	10 mm
Absolute max shaft load radial/axial	with solid shaft radial 90 N, axial 20 N with hollow shaft radial 90 N, axial 70 N
Balance tolerances	axial ± 0.5 mm, radial ± 0.1 mm
Maximum speed	12,000 RPM
Torque	≤ 1 Ncm
Protection class	IP 40
General design	as per DIN EN 61010-1
Operating temperature	-15 up to +120 °C
Vibration (IEC 68-2-6)	≤ 100 m/s ²
Shock (IEC 68-2-27)	≤ 1,000 m/s ²
Housing material	Aluminium
Connection	PCB connector + cable
Size	Ø 53.5 mm
Weight	170 g approx.
Technical data – electrical	
Supply voltage (SELV)	5 VDC ±10%
Current consumption	max. 120 mA
Incremental signals A, B	Sine - Cosine 1 Vpp
Increments	2,048
Accuracy	±35"
Repeatability	±7"
Max. frequency	500 kHz
Reference signal: R	> 0.4 V (1 pulse/turn)
Commutation signal: C, D	Sine - Cosine 1 Vpp (1 period/turn)
Page	202



- Practically no speed limitation, since up to 12.000 1/min
- Very good dynamic behaviour through low moment of inertia of rotor and its minimal influence on the motor
- Very good drive stiffness since no coupling is used
- Compact size
- Excellent price-performance ratio
- Increased temperature range, -40 to + 120°C
- Incomparable shaft play tolerances (to 0.7 mm axial)
- Better frequency, 200 KHz
- Flexibility, since the user can integrate in all actual motor sizes
- Simple mounting and adjustment since encoders come aligned and gapped

TECHNICAL DATA mechanical

Weight	23 g without cover, 28 g with cover
Dimensions	
Outer diameter	39.6 mm with cover, 37.1 mm without cover
Depth	27.9 mm with cover ¹⁾ , 24.1 without cover
Hub diameters	6 mm / 8 mm / 10 mm / 3.18 mm (¹ / ₁₆ ") / 4.76 mm (³ / ₁₆ ") / 6.35 mm (¹ / ₄ ") / 9.52 mm (³ / ₈ ")
Hollow shaft tolerance	+0.026 mm ... -0.000 mm
Length of mounting shaft	min. 12 mm max. 22 mm when used with closed cover
Shaft misalignment	+ 0.38 mm ... - 0.38 mm axial endplay ²⁾ : + 0.13 mm ... - 0.38 mm radial runout: 0.05 mm (incl. angular misalignment)
Alignment of encoder channels to motor windings	coarse alignment: index mark on hub fine alignment: +/- 15° mechanical alignment range
Maximum speed	12.000 RPM
Moment of inertia	4.7 gcm ²
Protection class (EN 60529)	IP 40 when mounted with cover
Operating temperature	-40 ... + 120 °C
Stock temperature	-40 ... + 120 °C
Vibration proof (IEC 68-2-6)	25 m/s ² (5 ... 2000 Hz)
Shock resistance /IEC 68-2-27)	500 m/s ² (11 ms)
Type of connection	shielded cable radial or dual row connector ³⁾
Housing	glassfibre reinforced plastic

¹⁾ for radial cable connection

²⁾ + means away from mounting face

³⁾ 10 pins (incremental only), 14 pins for type M 15 (incremental + commutation), 16 pins for type M 21 (incremental + commutation)

TECHNICAL DATA
 electrical

General design	as per DIN EN 61010, protection class III, contamination Level 2, overvoltage class II
Supply voltage	5 or 12 V DC +/- 10% (SELV)
Intrinsic power consumption	Incremental: max. 100 mA Incremental + commutation: max. 120 mA
Recommended external fuse	T 0.125 A
Pulses	Incremental 200, 400, 500, 1000, 1024 optional 4, 6 or 8 pole commutation channels
Output circuit	NPN Open-Collector, max. 16 mA RS 422, max. 40 mA
Output signals	
Incremental	NPN-O.C: A, B, N / RS 422: A, B, N, \bar{A} , \bar{B} , \bar{N}
Commutation (optional)	NPN-O.C: U, V, W / RS 422: U, V, W, \bar{U} , \bar{V} , \bar{W}
Tolerance	
Incremental signals	max. +/- 5 arc-mins. (edge to any edge)
Commutation signals	max. +/- 6 arc-mins.
Phasing	
Incremental signals (A to B) [° electrical]	90° +/- 18° electrical
Commutation signals [° mechanical]	8 pole: 30°, 6 pole: 40°, 4 pole: 60°
Index to U [° mechanical]	+/- 1° mechanical (index center to signal falling edge)
Pulse width	
Incremental signals [° electrical]	180° +/- 18°
Commutation signals [° mechanical]	8 pole: 45°, 6 pole: 60°, 4 pole: 90°
Max. pulse frequency	200 kHz
Noise immunity ¹⁾	as per EN 50082-2 (1995 edition)
Noise emission ¹⁾	as per EN 50081-2 (1993 edition)

¹⁾ EMC values are only valid for versions with RS 422 output and screened cable.

DIMENSIONED DRAWING

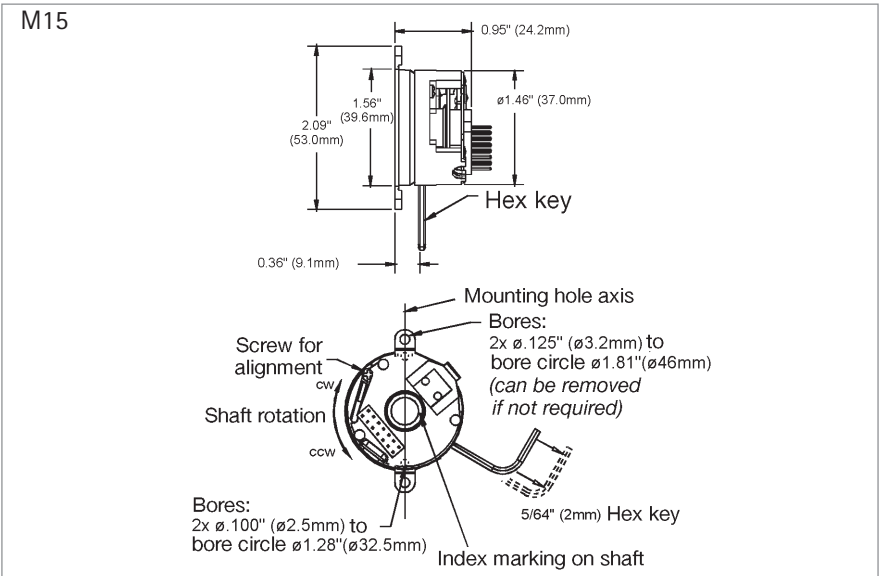

PULSE DIAGRAM

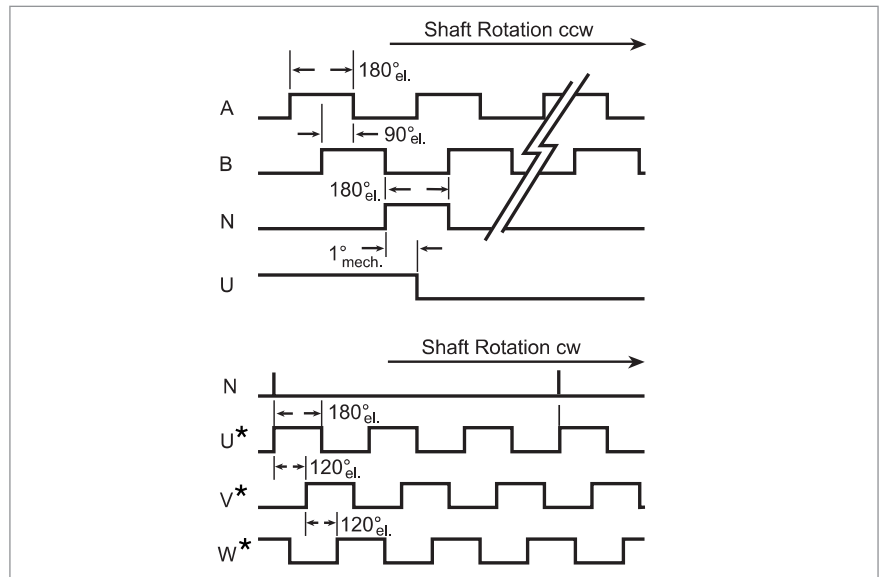

* Example with 6 pole commutation

CONNECTION DIAGRAM CABLE

Function	Colour incremental only, Code Electrical = 0, 1, 3	Colour incremental + commutation, Code Electrical = 6, 7, 9
V _{cccom} ¹⁾		red/white ³⁾
V _{ccinc} ¹⁾	red	red
GND inc	black	black
GND com		black/white ³⁾
\bar{A} ²⁾	red/black	blue/black
A	green	blue
\bar{B} ²⁾	white/black	green/black
B	orange	green
\bar{N} ²⁾	blue	violet/black
N	white	violet
\bar{U} ²⁾		brown/black
U		brown
\bar{V} ²⁾		grey/black
V		grey
\bar{W} ²⁾		white/black
W		white

¹⁾ V_{cccom} resp. V_{ccinc} = +5 V DC or +12 V DC (see Ordering data Electrical)

²⁾ only with Output_{inc/com} = RS 422

³⁾ hot applicable for Code 6 and 9, as here U_{inc} = U_{com}

CONNECTION DIAGRAM DUAL ROW CONNECTOR

Pin ¹⁾	10 poles Incr. only, NPN-O.C., Code Electr.= 0, 1	10 poles Incr. only,, RS422, Code Electr.= 3	14 poles Incr.+Commutation, Code Electr.= 6, 7, 9
1	A		V _{cc}
2	V _{cc}	V _{cc}	U
3	GND	GND	\bar{U}
4			V
5		\bar{A}	\bar{V}
6		A	W
7		\bar{B}	\bar{W}
8	B	B	\bar{A}
9		\bar{N}	A
10	N	N	B
11			\bar{B}
12			N
13			GND
14			\bar{N}

Dual row connector 10 poles

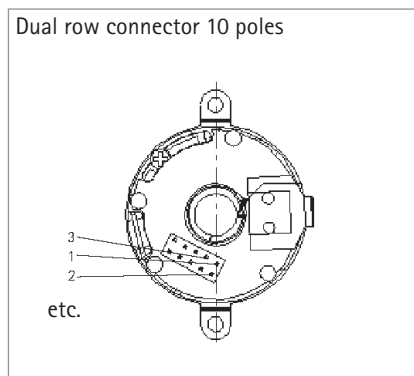

Dual row connector 14 poles

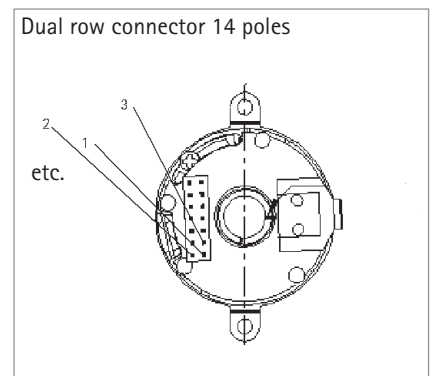

ORDERING DATA

	Cover 0 no cover 1 closed cover for blind shaft 2 cover with bore for through shaft	Type of connection 0 dual row connector 1...8 connector with mating ribbon cable 1=30 cm, 2=60 cm, ... A...H screened radial cable A=30 cm, B=60 cm, ...
--	--	---

M15 - [] / [] - [] [] [] [] []

Pulses / Poles
Incremental / Commutation

0200/0
0400/0
0500/0
1000/0
1024/0
0500/6
1000/4
1000/6
1000/8
1024/4
1024/6
1024/8

Electrical ¹⁾

only incremental:

0 $U_{inc}=5\text{ V}$; output_{inc}=NPN-O.C.
1 $U_{inc}=12\text{ V}$; output_{inc}=NPN-O.C.
3 $U_{inc}=5\text{ V}$; output_{inc}=RS 422

incremental + commutation:

6 $U_{inc}=5\text{ V}$; output_{inc}=RS 422,
 $U_{com}=5\text{ V}$; output_{com}=NPN-O.C.
7 $U_{inc}=5\text{ V}$; output_{inc}=RS 422,
 $U_{com}=12\text{ V}$; output_{com}=NPN-O.C.
9 $U_{inc}=5\text{ V}$; output_{inc}=RS 422,
 $U_{com}=5\text{ V}$; output_{com}=RS 422

Hub diameter

0 6.35 mm ($\frac{1}{4}''$)
1 9.52 mm ($\frac{3}{16}''$)
4 6 mm
5 8 mm
6 10 mm
8 4.76 mm ($\frac{3}{16}''$)
9 3.18 mm ($\frac{1}{8}''$)

¹⁾ U_{inc} : supply voltage incremental
 U_{com} : supply voltage commutation (only if commutation is selected)

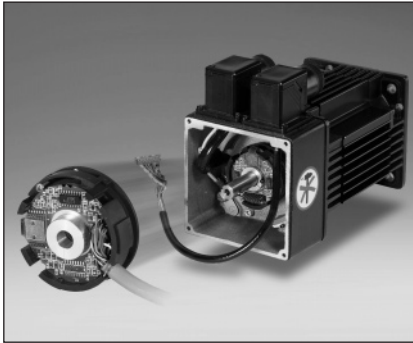

- Modular hollow shaft encoder as feedback for Brushless DC (BLDC) Servos, DC Servos and Step Motors
- Output signals: A, B, N incremental channels with index standard
Optional 4, 6, 8 or 12 pole commutation channels U, V, W
- Outside diameter 53 mm (2.1")
- Hub diameters 6 ... 12 mm (1/4" ... 1/2")
- Height 20 mm (0,8")
- Resolution 500 ... 2048 lines
- Standard Operating temperature -40 ... +120 °C
- Maximum speed 12000 RPM
- Easy installation and alignment
- New: Motor encoder M15 with external diameter 38 mm (1.5") on request

NUMBER OF PULSES

500, 1000, 1024, 2000, 2048
Optional 4, 6, 8 or 12 PPR commutation channels

TECHNICAL DATA mechanical

Weight	28 g without cover, 43 g with cover
Dimensions	
Outside diameter	51 mm without cover, 53 mm with cover
Height	20.3 mm with cover excluding connector, 17.9 mm without cover
Hub diameters	6 mm / 8 mm / 10 mm / 12 mm / 6.35 mm (1/4") / 9.52 mm (3/8") / 11.11 mm (7/16") / 12.7 mm (1/2")
Hub tolerance	+0.026 mm ... - 0.000 mm
Shaft endplay	Misalignment axial: + 0.13 mm ¹⁾ ... - 0.38 mm
Shaft runout	Misalignment radial: 0.05 mm (incl. angular misalignment)
Length of mounting shaft	16.5 mm min., 19 mm max. when used with closed cover
Alignment of encoder channels to motor windings	coarse alignment: index mark on the housing and disc/hub; fine alignment: ± 15° mechanical alignment range
Maximum speed	12,000 RPM
Moment of inertia	4.7 gcm ²
Protection class (EN 60529)	IP 40 ²⁾ , when mounted with cover
Operating temperature	-40 ... +120 °C
Storage temperature	-40 ... +120 °C
Vibration proof (IEC 68-2-6)	25 m/s ² (5 ... 2,000 Hz)
Shock resistance (IEC 68-2-27)	500 m/s ² (11 ms)
Type of connection	shielded cable radial or dual row connector ³⁾
Housing	glassfibre reinforced plastic

¹⁾ + indicates away from mounting face

²⁾ IP 50 on request

³⁾ 10 pins (incremental only), 16 pins (incremental+commutation)

TECHNICAL DATA
electrical

General design	as per DIN EN 61010, protection class III, contamination Level 2, overvoltage class II	
Supply voltage	5 or 12 V DC $\pm 10\%$ (SELV)	
Intrinsic power consumption	incremental: 100 mA max.; commutation: 75 mA max.	
Recommended external fuse	2 x T 0.125 A	
Output circuit	NPN-Open Collector, 16 mA max.; RS 422, 40 mA max.	
Output signals		
Incremental	NPN-O.C: A, B, N	RS 422: A, B, N, \bar{A} , \bar{B} , \bar{N}
Commutation (optional):	NPN-O.C: U, V, W	RS 422: U, V, W, \bar{U} , \bar{V} , \bar{W}
Tolerance		
Incremental signals	± 5 arc-mins. max. (edge to any edge)	
Commutation signals	± 6 arc-mins. max.	
Phasing		
Incremental signals (A to B)	$90^\circ \pm 18^\circ$ electrical	
Commutation signals	12 pole: 20° , 8 pole: 30° , 6 pole: 40° , 4 pole: 60° mechanical	
Index to U	$\pm 1^\circ$ mechanical (index center to U signal falling edge)	
Pulse width		
Incremental signals	$180^\circ \pm 18^\circ$ electrical	
Commutation signals	12 pole: 30° , 8 pole: 45° , 6 pole: 60° , 4 pole: 90° mechanical	
Max. pulse frequency	200 kHz	
Noise immunity ¹⁾	according EN 50082-2	
Noise emission ¹⁾	according EN 50081-2	

¹⁾ EMC values are valid for versions with RS 422 output and screened cable.

DIMENSIONED DRAWING

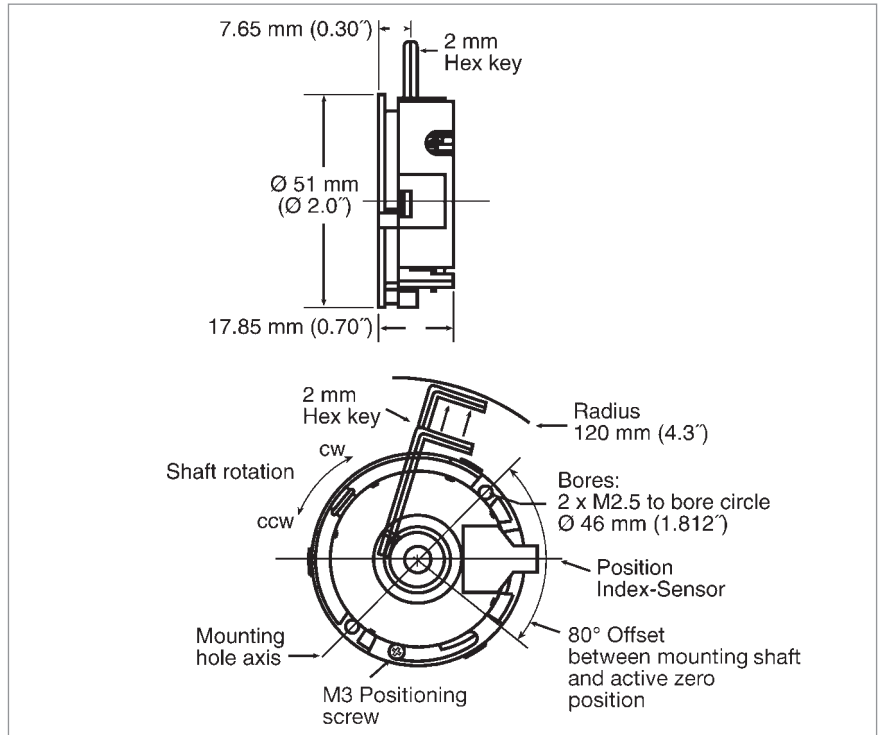

PULSE DIAGRAM

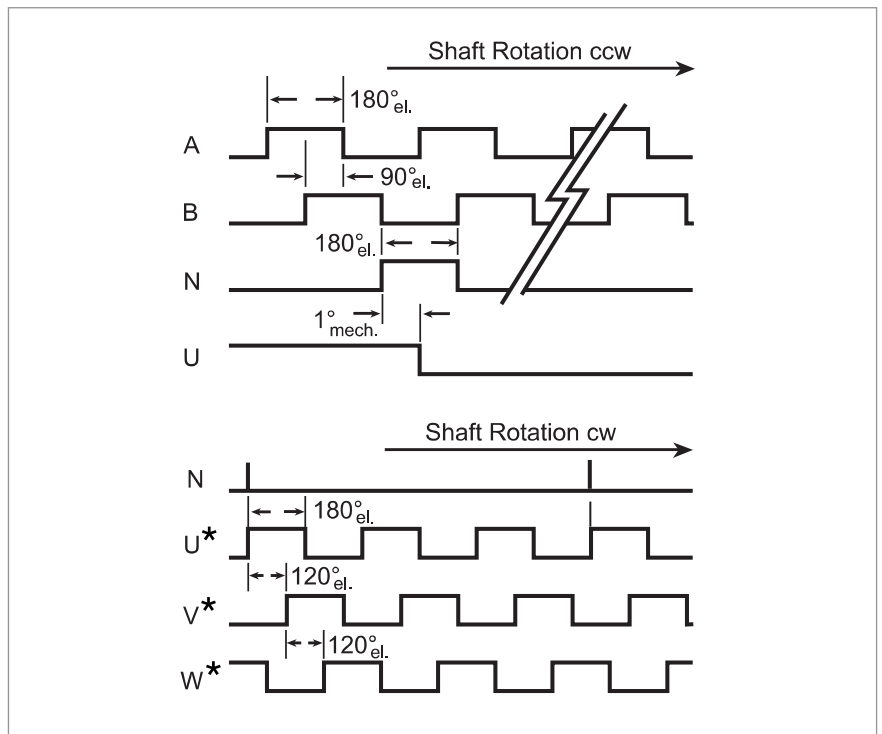

* Example with 6 pole commutation

CONNECTION DIAGRAM CABLE

Function	colour incremental only, code electrical = 3	colour incremental + commutation, code electrical = 6, 7, 9, A
V _{CCcom} ¹⁾		red/white ³⁾
V _{CCinc} ¹⁾	red	red
GND inc	black	black
GND com		black/white ³⁾
\bar{A}	red/black	blue/black
A	green	blue
\bar{B}	white/black	green/black
B	orange	green
\bar{N}	blue	violet/black
N	white	violet
\bar{U} ²⁾		brown/black
U		brown
\bar{V} ²⁾		grey/black
V		grey
\bar{W} ²⁾		white/black
W		white

¹⁾ V_{CCcom} resp. V_{CCinc} = +5 V DC or +12 V DC (see Ordering data Electrical)

²⁾ only for output_{com} = RS422

³⁾ not connected for codes 6 and 9, since here U_{inc} = U_{com}

CONNECTION DIAGRAM CONNECTOR

Function	10 poles incr. only, NPN-O.C., code electr.= 0, 1	10 poles incr. only, RS422, code electr.= 3	16 poles incr.+ commutation code electr.= 6, 7, 9
V _{CCcom} ¹⁾			1
V _{CCinc} ¹⁾	2	2	2
GND inc	3	3	3
GND com			4
\bar{A} ²⁾		5	5
A	1	1	6
\bar{B} ²⁾		7	7
B	8	8	8
\bar{N} ²⁾		9	9
N	10	10	10
\bar{U} ²⁾			11
U			12
\bar{V} ²⁾			13
V			14
\bar{W} ²⁾			15
W			16

¹⁾ V_{CCcom} resp. V_{CCinc} = +5 V DC or +12 V DC (see Ordering data Electrical)

²⁾ Only for Output_{inc/com} = RS422

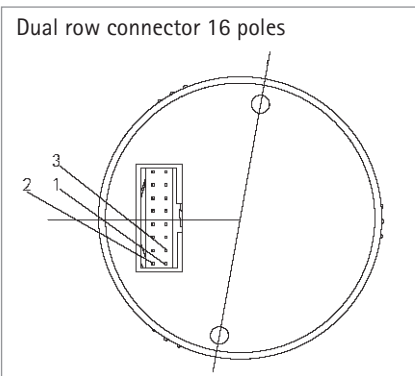

ORDERING DATA

Pulses	Poles	Cover	Type of connection
incremental	commutation	0 no cover	0 dual row connector ⁵⁾
0500	0 without	1 closed cover	1...8 connector with mating ribbon cable ⁵⁾
1000	4 4 pole	for blind shaft	1=30 cm (1 ft.), 2=60 cm (2 ft.), ...
1024	6 6 pole	2 cover with bore	A...H screened cable radial ³⁾
2000	8 8 pole	for through shaft	A=30 cm (1 ft.), B=60 cm (2 ft.), ...
2048	C 12 pole ⁴⁾		

Electrical¹⁾

incremental only	0	$U_{inc}=5\text{ V}$; output _{inc} =NPN-O.C.
	1	$U_{inc}=12\text{ V}$; output _{inc} =NPN-O.C.
	3	$U_{inc}=5\text{ V}$; output _{inc} =RS 422
incremental+ commutation	6	$U_{inc}=5\text{ V}$, output _{inc} =RS 422; $U_{com}=5\text{ V}$, output _{com} =NPN-O.C.
	7	$U_{inc}=5\text{ V}$, output _{inc} =RS 422; $U_{com}=12\text{ V}$, output _{com} =NPN-O.C.
	9	$U_{inc}=5\text{ V}$, output _{inc} =RS 422; $U_{com}=5\text{ V}$, output _{com} =RS 422
	A	same as code 9 but with EEPROM

Hub diameter²⁾

A	6,35 mm (1/4")
B	9,52 mm (3/8")
C	11,11 mm (7/16")
D	12,7 mm (1/2")
E	6 mm
F	8 mm
G	10 mm
H	12 mm

¹⁾ U_{inc} : supply voltage incremental, ⁴⁾ only possible with 1024 and 2048 pulses
 U_{com} : supply voltage commutation (only if commutation is selected) ⁵⁾ not possible with Electrical code = A
²⁾ Exposed hub clamp screw
³⁾ only possible with output=RS 422 (code for Electrical ≥ 3)

Selection Guide

No. of lines	Poles				
	0	4	6	8	12 (=C)
0500	X	X	X	X	
0512	X			X	
1000	X	X	X	X	
1024	X	X	X	X	X
2000	X	X	X	X	
2048	X	X	X	X	X



- Wide operating temperature range of $-15\text{ }^{\circ}\text{C}$ up to $+120\text{ }^{\circ}\text{C}$, therefore optimum use of motor capacity
- High limiting frequency with excellent signal quality, allowing highest peak speeds and reduced non-productive time wastage
- Excellent immunity to interference (EN 61000-4-4, Class 4)
- High functional safety due to signal control and system monitoring (under-voltage, pollution, disc damage, end of LED service life)
- High signal quality through control and error compensation

The S21 has been constructed in line with the International Standard Resolver dimension 21, i.e. 2.1" (approx. 53 mm) and as a result is also suitable for smaller sized motors. The simplicity of connection rounds off advantages of the S21. The integrated cable plug connector combines the advantages of the plug with those of a cable connection. This leads to a fast, economical and space-saving installation.

TECHNICAL DATA Electrical

General Design	acc. DIN EN 61010-1, protection class III, contamination level 2, overvoltage category II
Supply voltage	5 V \pm 10 %
Current consumption	max. 120 mA
Incremental signals: A, B	Sine - Cosine 1Vpp
Increments	2048
Accuracy	\pm 35"
Repeatability	\pm 7"
Max. frequency	500 kHz
Reference signal: R	$> 0.4\text{ V}$ (1 pulse per rev.)
Commutation signal: C, D	Sine - Cosine 1Vpp (1 period per rev.)
Connection	PCB connector with cable

TECHNICAL DATA Mechanical

Shaft form	Conical 1/10
Shaft variations	Hollow and solid
Shaft diameter	10 mm
Shaft load	radial 90 N, axial 20 N
Compensation	axial \pm 0.5 mm, radial \pm 0.1 mm
Nominal speed	12.000 min^{-1}
Maximum speed	15.000 min^{-1} (short time)
Torque	$\leq 1\text{ Ncm}$
Protection class	IP 40
Operating temperature	$-15\text{ }^{\circ}\text{C}$... $+120\text{ }^{\circ}\text{C}$
Storage temperature	... $-20\text{ }^{\circ}\text{C}$ $+80\text{ }^{\circ}\text{C}$
Vibration (IEC 68-2-6)	$\leq 100\text{ m/s}^2$ (10 ... 2000 Hz)
Shock (IEC 68-2-27)	$\leq 1000\text{ m/s}^2$ (6 ms)
Housing material	Aluminium

S21 SIGNALS

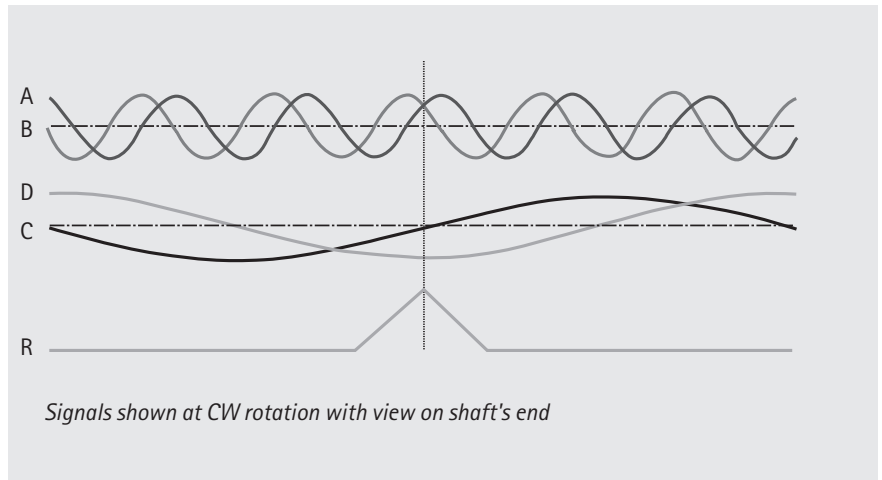

The incremental signals A and B and the zero signal R are differential voltage signals. The differential signal level is 1Vpp. The zero signal appears once per revolution and reaches its maximum value at the angle where the amplitudes of A and B Signals are equal. The coarse tracks C and D deliver one sinewave period per revolution and are utilized to determine the absolute rotor position of Brushless DC motors for startup commutation. All signals have a DC offset of 2.5 V.

S21 SIGNAL QUALITY

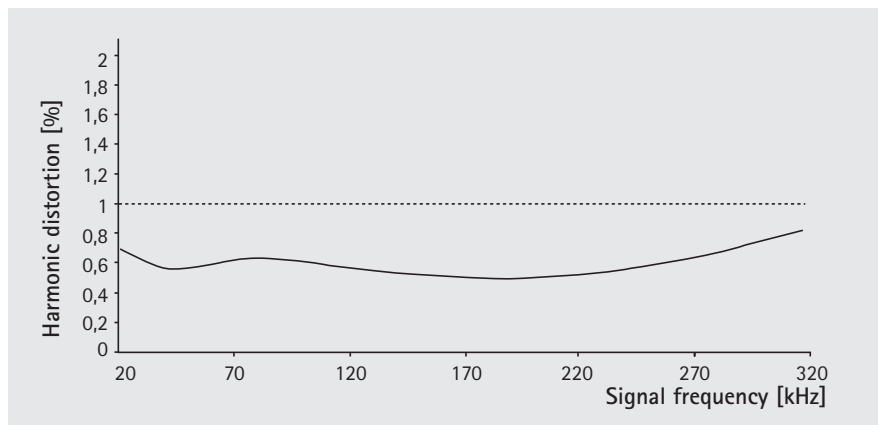

The quality of the servo loop is determined to a large extent by the absence of harmonics in the encoder's sinewave signals, particularly at low speed. In order to achieve high interpolation factors in the sequencing control, the incremental sinewave signals A and B are available with a harmonic distortion significantly under 1% throughout the specified temperature range. This delivers excellent synchronism and a high level of positional accuracy with servo axes.

PCB – CONNECTOR PIN OUT:

Row b	5 V Sense rt/bl	D- vio	B- rd	R- pk	0 V Sense gn/br	A- ye	C- br
Row a	wt C+	gn A+	wt/gn GND	gr R+	bl B+	bk D+	gr/pk U _B

DIMENSIONED DRAWINGS SOLID SHAFT

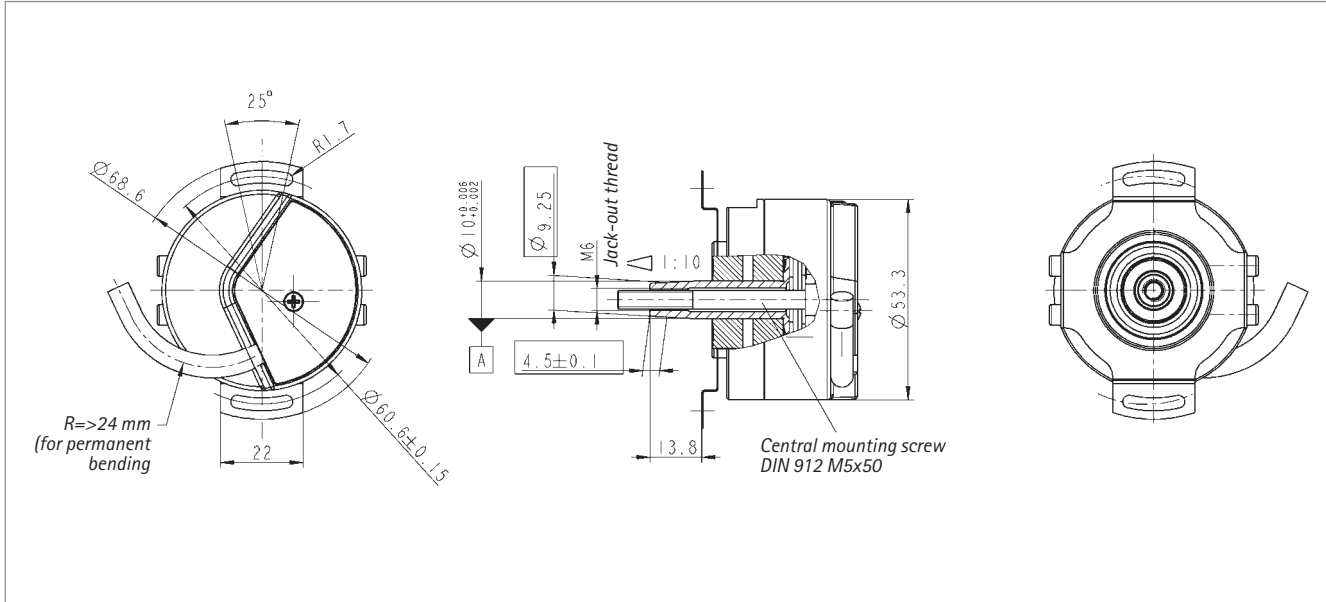

DIMENSIONED DRAWINGS HOLLOW SHAFT

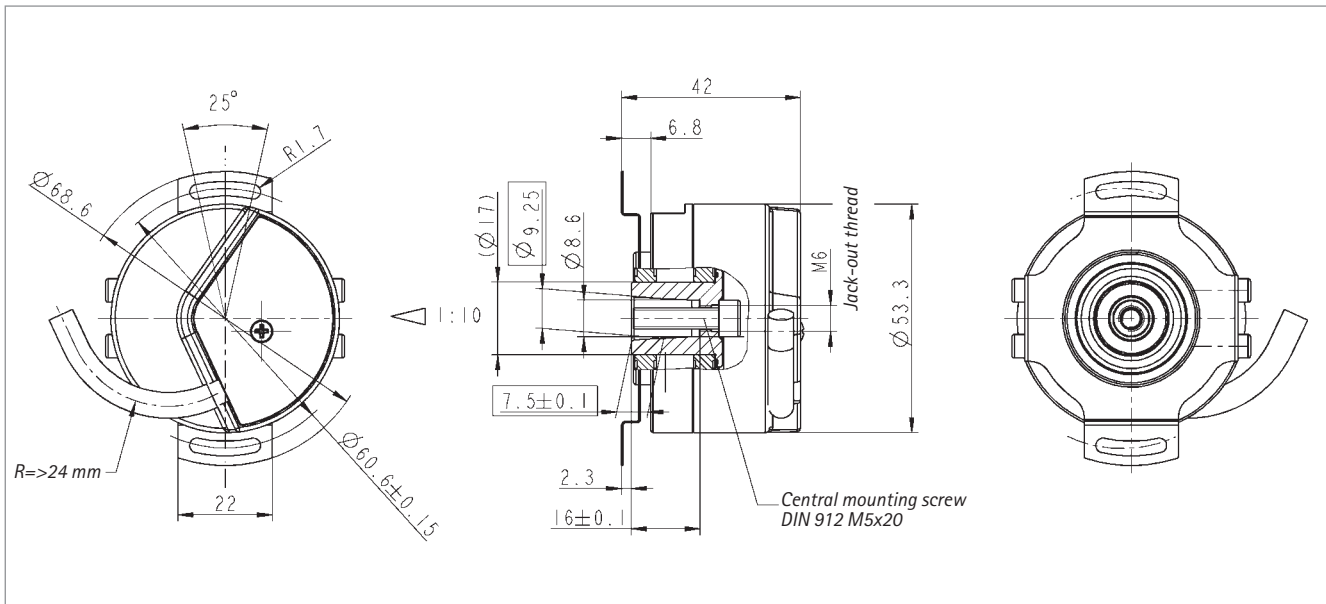

ORDERING CODE:

Solid shaft, with mounting support	0 548 011
Hollow shaft, with mounting support	0 548 021